

Rexroth ADF1x4 Liquid Cooled Asynchronous Motors

R911273934
Edition 01

Project Planning Manual



Title Liquid Cooled Asynchronous Motors ADF
Motor Line ADF1x4

Type of Documentation Project Planning Manual

Document Typecode DOK-MOTOR*-ADF1x4*****-PR01-EN-P

Internal File Reference

- 27393401_Book.doc
- Document Number 120-1500-B318-01/EN

Purpose of Documentation This documentation ...

- explains product features and applications, technical data as well as conditions and limits for operation.
- provides guidelines for product selection, application, handling and operation.

Record of Revisions

Description	Release Date	Notes
DOK-MOTOR*-ADF1x4*****-PR01-EN-P	10.2001	1 st edition for motor series ADF1x4

Copyright © 2001 Rexroth Indramat GmbH

Copying this document, giving it to others and the use or communication of the contents thereof without express authority, are forbidden. Offenders are liable for the payment of damages. All rights are reserved in the event of the grant of a patent or the registration of a utility model or design (DIN 34-1).

Validity The specified data is for product description purposes only and may not be deemed to be guaranteed unless expressly confirmed in the contract. All rights are reserved with respect to the content of this documentation and the availability of the product.

Published by Rexroth Indramat GmbH
Bgm.-Dr.-Nebel-Str. 2 • D-97816 Lohr a. Main
Telephone +49 (0)93 52/40-0 • Tx 68 94 21 • Fax +49 (0)93 52/40-48 85
<http://www.boschrexroth.de/>
Dept. EDM1 (MS)

Note This document has been printed on chlorine-free bleached paper.

Table of Contents

1	Introduction	1-1
1.1	Power gradation	1-1
1.2	Operation characteristic	1-2
1.3	Documentation	1-3
2	Important directions for use	2-1
2.1	Appropriate use	2-1
2.2	Inappropriate use	2-2
3	Safety Instructions for Electric Servo Drives and Controls	3-1
3.1	Introduction.....	3-1
3.2	Explanations.....	3-1
3.3	Hazards by inappropriate use	3-2
3.4	General Information	3-3
3.5	Protection against contact with electrical parts.....	3-4
3.6	Protection by protective low voltage (PELV) against electrical shock	3-6
3.7	Protection against dangerous movements.....	3-6
3.8	Protection against magnetic and electromagnetic fields during operations and mounting.....	3-8
3.9	Protection against contact with hot parts	3-9
3.10	Protection during handling and installation	3-9
3.11	Battery safety	3-10
3.12	Protection against pressurized Systems.....	3-10
4	Type Code ADF	4-1
4.1	Product.....	4-1
4.2	Motor Size	4-1
4.3	Length of Motor	4-1
4.4	Type	4-1
4.5	Position of the Power Connection.....	4-2
4.6	Output Direction of Power Connection.....	4-2
4.7	Coolant connection	4-3
4.8	Windings code.....	4-3
4.9	Holding Brake.....	4-3
4.10	Motor Feedback	4-3
4.11	Drive Shaft	4-4
4.12	Shaft End Side B.....	4-4
4.13	Bearings	4-4
4.14	Vibration severity grade	4-4

5	Technical Data ADF104	5-1
5.1	Data Sheet	5-1
5.2	Type Code ADF104	5-2
5.3	Dimensions Sheet ADF104.....	5-4
5.4	Grease Life.....	5-5
5.5	Shaft Load.....	5-6
6	Technical Data ADF134	6-1
6.1	Data Sheet	6-1
6.2	Type Code ADF134	6-2
6.3	Dimensions Sheet ADF134 (Flange Socket).....	6-4
6.4	Dimensions Sheet ADF134 (Terminal Box, no Encoder)	6-5
6.5	Dimensions Sheet ADF134 (Terminal Box).....	6-6
6.6	Grease Life.....	6-7
6.7	Shaft Load.....	6-8
7	Technical Data ADF164	7-1
7.1	Data Sheet	7-1
7.2	Type Code ADF164	7-2
7.3	Dimensions Sheet ADF164 (Terminal Box).....	7-4
7.4	Grease Life.....	7-5
7.5	Shaft Load.....	7-6
8	Technical Data ADF184	8-1
8.1	Data Sheet	8-1
8.2	Type Code ADF184	8-2
8.3	Dimensions Sheet ADF184 (Terminal Box).....	8-4
8.4	Grease Life.....	8-5
8.5	Shaft Load.....	8-6
9	Accessories	9-1
9.1	Labyrinth Seal	9-1
10	Connections	10-1
10.1	Notes	10-1
10.2	Power Connection.....	10-2
10.3	ADF with Power Flange Socket	10-3
10.4	ADF with Terminal Box	10-5
10.5	Encoder Connection.....	10-8
10.6	Brake.....	10-9
10.7	Temperature Sensor	10-9
10.8	Motor Cooling.....	10-10
11	Application Guidelines	11-1
11.1	Operating Conditions	11-1
11.2	Class of protection	11-3

11.3	Installation in the Machine.....	11-4
11.4	Brakes	11-7
11.5	Motor Encoder.....	11-9
11.6	Drive Shaft	11-10
11.7	Bearing and Shaft Load	11-12
11.8	Vibration Level	11-17
11.9	Temperature Sensor	11-17
11.10	Motor Cooling.....	11-18
12	Handling and Transport	12-1
12.1	Condition on Delivery	12-1
12.2	Identification.....	12-2
12.3	Transport and Storage	12-2
13	Installation	13-1
13.1	Safety	13-1
13.2	Mechanical Installation.....	13-1
13.3	Electrical Connection	13-3
14	Operation of ADF Motors	14-1
14.1	Commissioning.....	14-1
14.2	Shutdown	14-2
14.3	Disassembly.....	14-2
14.4	Maintenance.....	14-3
14.5	Troubleshooting	14-4
15	Service & Support	15-1
15.1	Helpdesk	15-1
15.2	Service-Hotline.....	15-1
15.3	Internet	15-1
15.4	Vor der Kontaktaufnahme... - Before contacting us.....	15-1
15.5	Kundenbetreuungsstellen - Sales & Service Facilities	15-2
16	Appendix	16-1
16.1	List of standards.....	16-1
17	Glossary	17-1
18	Index	18-1

1 Introduction

The ADF product line consists of asynchronous housing motors with squirrel-cage and liquid cooling. The motors of the ADF1x4 product line are suitable for operation on drive controllers from the ECODRIVE and DIAX04 line with a high DC-bus voltage of up to 750 V_{DC}.



Fig. 1-1: Example of ADF134

The combination of ADF with DIAX04 or ECODRIVE systems provides intelligent drive solutions with a high power density and open functionality.

1.1 Power gradation

ADF motors are available in power ranges up to 81.7 kW.

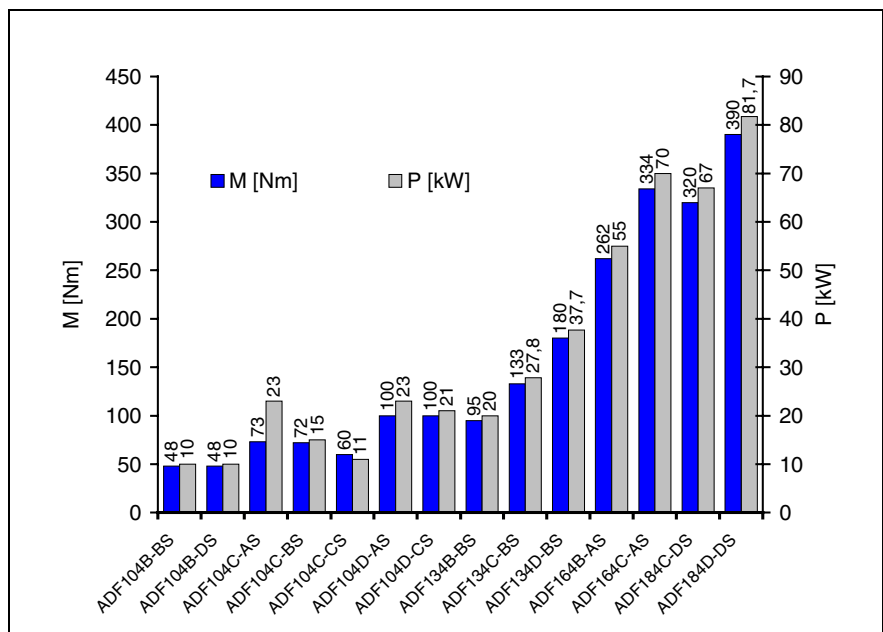
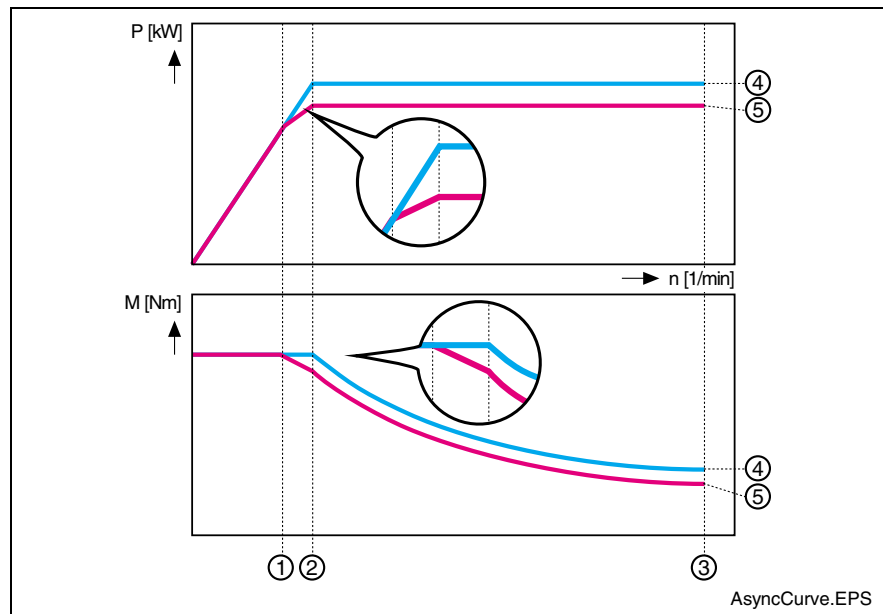

Fig. 1-2: ADF Power Gradation

Note: The details in data sheets of this documentation (chapters "Technical data ADF...") relate purely to the motor. The available performance of a drive system with motor, controller and power supply can be gathered from the corresponding selection data documentation.

1.2 Operation characteristic

Following curves provide examples of the operating characteristic of ADF motors as well as details from the motor data sheet.



P [kW]: mechanical power delivered in kilowatt

M [Nm]: available torque at the drive shaft in newton-meter

n [min⁻¹]: motor speed in revs per minute.

(1): derating speed (n_1 in the data sheet)

(2): rated speed (n_N in the data sheet)

(3): maximum speed

(4): curve without derating

(5): curve with derating

Fig. 1-3: ADF sample curves

Explanation

(1) Derating speed The start of a drop in torque and power before reaching the rated speed n_N . This behaviour is termed **derating** and only occurs with special types of motor winding. **Without derating, the derating speed is the same as the rated speed.**

Until the derating speed is reached, the standstill continuous current I_1 applies (effective value). **Without derating, the standstill continuous current is the same as the rated current I_N .**

Until the derating speed is reached, the standstill continuous torque M_1 is available for S1 operation. **Without derating, the standstill continuous current is the same as the rated torque M_N .**

With effective derating, both the power and the torque are reduced from the time at which the benchmark speed is reached. In Fig. 1-3, two characteristic curves are each shown from the point of the derating speed.

(2) Rated speed Without derating effect, asynchronous motors deliver a constant torque (rated torque) up to the rated speed. From rated speed on a constant **rated power P_N** is available.

(3) Maximum speed Speed limit up to which a motor can be safely operated. Normally limited by the mechanical design (bearing system).

1.3 Documentation

Summary

This documentation describes exclusively the ADF1x4 motor line with suitability for high DC-bus voltages.

Depending on the requirements, the following documentation also is required for planning drive systems using the ADF motor line.

Material No.:	Title / Description	Reference
00273934	DOK-MOTOR*-ADF1X4*****-PR <u>01</u> -EN-P "Project planning manual ADF, motor line 1x4..."	ADF
00271431	DOK-MOTOR*-ADF*****-PR <u>01</u> -EN-P "Project planning manual ADF..."	
00289233	DOK-DRIVE*-MAIN*WZM***-AU <u>02</u> -MS-E " AC main drives with 2AD- and ADF-motors"	Selection data
00288730 (in preparation)	DOK-DRIVE*-PRINT*****-AU <u>02</u> -MS-E "Druckmaschinenantriebe..."	
00259814	DOK-GENERL-EMV*****-PRJ <u>1</u> -EN-P " Electromagnetic Compatibility (EMC) in Drive and Control Systems"	EMV
00286117	DOK-CONNEX-CAB*INSTR02-MA <u>01</u> -EN-P "Cable assembly and tools for DIAX04 and ECODRIVE03"	Cables and connectors
00282688	DOK-CONNEX-CABLE*STAND-AU <u>04</u> -EN-P "Connecting Cables DIAX04, ECODRIVE03 and POWERDRIVE"	
1) The index (e.g. .. <u>02</u> -..) indicates the actual edition when this documentation was published.		

Fig. 1-4: Documentation summary



Request the actual documentation for the products you are using from your branch of REXROTH INDRAMAT (refer to address directory at the end of this manual).

Third-Party Systems

Documentation for external systems linked to REXROTH INDRAMAT components are not a part of the delivery and must be directly ordered from these manufacturers.

2 Important directions for use

2.1 Appropriate use

Introduction

Rexroth Indramat products represent state-of-the-art developments and manufacturing. They are tested prior to delivery to ensure operating safety and reliability.

The products may only be used in the manner that is defined as appropriate. If they are used in an inappropriate manner, then situations can develop that may lead to property damage or injury to personnel.

Note: Rexroth Indramat, as manufacturer, is not liable for any damages resulting from inappropriate use. In such cases, the guarantee and the right to payment of damages resulting from inappropriate use are forfeited. The user alone carries all responsibility of the risks.

Before using Rexroth Indramat products, make sure that all the prerequisites for appropriate use of the products are satisfied:

- Personnel that in any way, shape or form uses our products must first read and understand the relevant safety instructions and be familiar with appropriate use.
- If the product takes the form of hardware, then they must remain in their original state, in other words, no structural changes are permitted. It is not permitted to decompile software products or alter source codes.
- Do not mount damaged or faulty products or use them in operation.
- Make sure that the products have been installed in the manner described in the relevant documentation.

Areas of use and application

Asynchronous motors of the ADF line made by Rexroth Indramat are designed to be used as rotary main and servo drive motors. Typical applications are:

- machine tools,
- printing and paper processing machines,
- packaging and foodstuff machines and
- metal-forming machine tools.

Available for an application-specific use of the motors are unit types with differing drive power and different interfaces.

Control and monitoring of the motors may require additional sensors and actors.

Note: The motors may only be used with the accessories and parts specified in this document. If a component has not been specifically named, then it may not be either mounted or connected. The same applies to cables and lines.

Operation is only permitted in the specified configurations and combinations of components using the software and firmware as specified in the relevant function descriptions.

Every drive controller has to be programmed before starting it up, making it possible for the motor to execute the specific functions of an application.

The motors may only be operated under the assembly, installation and ambient conditions as described here (temperature, protection categories, humidity, EMC requirements, etc.) and in the position specified.

2.2 Inappropriate use

Using the motors outside of the above-referenced areas of application or under operating conditions other than described in the document and the technical data specified is defined as "inappropriate use".

ADF motors may not be used if

- they are subject to operating conditions that do not meet the specified ambient conditions. This includes, for example, operation under water, in the case of extreme temperature fluctuations or extremely high maximum temperatures or if
- Rexroth Indramat has not specifically released them for that intended purpose. Please note the specifications outlined in the general Safety Instructions!

3 Safety Instructions for Electric Drives and Controls

3.1 Introduction

Read these instructions before the initial startup of the equipment in order to eliminate the risk of bodily harm or material damage. Follow these safety instructions at all times.

Do not attempt to install or start up this equipment without first reading all documentation provided with the product. Read and understand these safety instructions and all user documentation of the equipment prior to working with the equipment at any time. If you do not have the user documentation for your equipment, contact your local Rexroth Indramat representative to send this documentation immediately to the person or persons responsible for the safe operation of this equipment.

If the equipment is resold, rented or transferred or passed on to others, then these safety instructions must be delivered with the equipment.



WARNING

Improper use of this equipment, failure to follow the safety instructions in this document or tampering with the product, including disabling of safety devices, may result in material damage, bodily harm, electric shock or even death!

3.2 Explanations

The safety instructions describe the following degrees of hazard seriousness in compliance with ANSI Z535. The degree of hazard seriousness informs about the consequences resulting from non-compliance with the safety instructions.

Warning symbol with signal word	Degree of hazard seriousness according to ANSI
 DANGER	Death or severe bodily harm will occur.
 WARNING	Death or severe bodily harm may occur.
 CAUTION	Bodily harm or material damage may occur.

Fig. 3-1: Hazard classification (according to ANSI Z535)

3.3 Hazards by Improper Use



DANGER

**High voltage and high discharge current!
Danger to life or severe bodily harm by electric shock!**



DANGER

Dangerous movements! Danger to life, severe bodily harm or material damage by unintentional motor movements!



WARNING

High electrical voltage due to wrong connections! Danger to life or bodily harm by electric shock!



WARNING

Health hazard for persons with heart pacemakers, metal implants and hearing aids in proximity to electrical equipment!



CAUTION

Surface of machine housing could be extremely hot! Danger of injury! Danger of burns!



CAUTION

Risk of injury due to improper handling! Bodily harm caused by crushing, shearing, cutting and mechanical shock or incorrect handling of pressurized systems!



CAUTION

Risk of injury due to incorrect handling of batteries!

3.4 General Information

Rexroth Indramat GmbH is not liable for damages resulting from failure to observe the warnings provided in this documentation.

Read the operating, maintenance and safety instructions in your language before starting up the machine. If you find that you cannot completely understand the documentation for your product, please ask your supplier to clarify.

Proper and correct transport, storage, assembly and installation as well as care in operation and maintenance are prerequisites for optimal and safe operation of this equipment.

Only persons who are trained and qualified for the use and operation of the equipment may work on this equipment or within its proximity. The persons are qualified if they have sufficient knowledge of the assembly, installation and operation of the equipment as well as an understanding of all warnings and precautionary measures noted in these instructions.

Furthermore, they must be trained, instructed and qualified to switch electrical circuits and equipment on and off in accordance with technical safety regulations, to ground them and to mark them according to the requirements of safe work practices. They must have adequate safety equipment and be trained in first aid.

Only use spare parts and accessories approved by the manufacturer.

Follow all safety regulations and requirements for the specific application as practiced in the country of use.

The equipment is designed for installation in industrial machinery.

The ambient conditions given in the product documentation must be observed.

Use only safety features and applications that are clearly and explicitly approved in the Project Planning Manual.

For example, the following areas of use are not permitted: construction cranes, elevators used for people or freight, devices and vehicles to transport people, medical applications, refinery plants, transport of hazardous goods, nuclear applications, applications sensitive to high frequency, mining, food processing, control of protection equipment (also in a machine).

The information given in this documentation with regard to the use of the delivered components contains only examples of applications and suggestions.

The machine and installation manufacturer must

- make sure that the delivered components are suited for his individual application and check the information given in this documentation with regard to the use of the components,
- make sure that his application complies with the applicable safety regulations and standards and carry out the required measures, modifications and complements.

Startup of the delivered components is only permitted once it is sure that the machine or installation in which they are installed complies with the national regulations, safety specifications and standards of the application.

Operation is only permitted if the national EMC regulations for the application are met.

The instructions for installation in accordance with EMC requirements can be found in the documentation "EMC in Drive and Control Systems."

The machine or installation manufacturer is responsible for compliance with the limiting values as prescribed in the national regulations.

Technical data, connections and operational conditions are specified in the product documentation and must be followed at all times.

3.5 Protection Against Contact with Electrical Parts

Note: This section refers to equipment and drive components with voltages above 50 Volts.

Touching live parts with voltages of 50 Volts and more with bare hands or conductive tools or touching ungrounded housings can be dangerous and cause electric shock. In order to operate electrical equipment, certain parts must unavoidably have dangerous voltages applied to them.



DANGER

High electrical voltage! Danger to life, severe bodily harm by electric shock!

- ⇒ Only those trained and qualified to work with or on electrical equipment are permitted to operate, maintain or repair this equipment.
 - ⇒ Follow general construction and safety regulations when working on high voltage installations.
 - ⇒ Before switching on power the ground wire must be permanently connected to all electrical units according to the connection diagram.
 - ⇒ Do not operate electrical equipment at any time, even for brief measurements or tests, if the ground wire is not permanently connected to the points of the components provided for this purpose.
 - ⇒ Before working with electrical parts with voltage higher than 50 V, the equipment must be disconnected from the mains voltage or power supply. Make sure the equipment cannot be switched on again unintended.
 - ⇒ The following should be observed with electrical drive and filter components:
 - ⇒ Wait five (5) minutes after switching off power to allow capacitors to discharge before beginning to work. Measure the voltage on the capacitors before beginning to work to make sure that the equipment is safe to touch.
 - ⇒ Never touch the electrical connection points of a component while power is turned on.
 - ⇒ Install the covers and guards provided with the equipment properly before switching the equipment on. Prevent contact with live parts at any time.
 - ⇒ A residual-current-operated protective device (RCD) must not be used on electric drives! Indirect contact must be prevented by other means, for example, by an overcurrent protective device.
 - ⇒ Electrical components with exposed live parts and uncovered high voltage terminals must be installed in a protective housing, for example, in a control cabinet.
-

To be observed with electrical drive and filter components:



DANGER

**High electrical voltage on the housing!
High leakage current! Danger to life, danger of
injury by electric shock!**

- ⇒ Connect the electrical equipment, the housings of all electrical units and motors permanently with the safety conductor at the ground points before power is switched on. Look at the connection diagram. This is even necessary for brief tests.
- ⇒ Connect the safety conductor of the electrical equipment always permanently and firmly to the supply mains. Leakage current exceeds 3.5 mA in normal operation.
- ⇒ Use a copper conductor with at least 10 mm² cross section over its entire course for this safety conductor connection!
- ⇒ Prior to startups, even for brief tests, always connect the protective conductor or connect with ground wire. Otherwise, high voltages can occur on the housing that lead to electric shock.

3.6 Protection Against Electric Shock by Protective Low Voltage (PELV)

All connections and terminals with voltages between 0 and 50 Volts on Rexroth Indramat products are protective low voltages designed in accordance with international standards on electrical safety.



WARNING

**High electrical voltage due to wrong
connections! Danger to life, bodily harm by
electric shock!**

- ⇒ Only connect equipment, electrical components and cables of the protective low voltage type (PELV = Protective Extra Low Voltage) to all terminals and clamps with voltages of 0 to 50 Volts.
- ⇒ Only electrical circuits may be connected which are safely isolated against high voltage circuits. Safe isolation is achieved, for example, with an isolating transformer, an opto-electronic coupler or when battery-operated.

3.7 Protection Against Dangerous Movements

Dangerous movements can be caused by faulty control of the connected motors. Some common examples are:

- improper or wrong wiring of cable connections
- incorrect operation of the equipment components
- wrong input of parameters before operation
- malfunction of sensors, encoders and monitoring devices
- defective components
- software or firmware errors

Dangerous movements can occur immediately after equipment is switched on or even after an unspecified time of trouble-free operation.

The monitoring in the drive components will normally be sufficient to avoid faulty operation in the connected drives. Regarding personal safety, especially the danger of bodily injury and material damage, this alone cannot be relied upon to ensure complete safety. Until the integrated monitoring functions become effective, it must be assumed in any case that faulty drive movements will occur. The extent of faulty drive movements depends upon the type of control and the state of operation.

**DANGER****Dangerous movements! Danger to life, risk of injury, severe bodily harm or material damage!**

- ⇒ Ensure personal safety by means of qualified and tested higher-level monitoring devices or measures integrated in the installation. Unintended machine motion is possible if monitoring devices are disabled, bypassed or not activated.
 - ⇒ Pay attention to unintended machine motion or other malfunction in any mode of operation.

 - ⇒ Keep free and clear of the machine's range of motion and moving parts. Possible measures to prevent people from accidentally entering the machine's range of motion:
 - use safety fences
 - use safety guards
 - use protective coverings
 - install light curtains or light barriers
 - ⇒ Fences and coverings must be strong enough to resist maximum possible momentum, especially if there is a possibility of loose parts flying off.
 - ⇒ Mount the emergency stop switch in the immediate reach of the operator. Verify that the emergency stop works before startup. Don't operate the machine if the emergency stop is not working.
 - ⇒ Isolate the drive power connection by means of an emergency stop circuit or use a starting lockout to prevent unintentional start.
 - ⇒ Make sure that the drives are brought to a safe standstill before accessing or entering the danger zone. Safe standstill can be achieved by switching off the power supply contactor or by safe mechanical locking of moving parts.
 - ⇒ Secure vertical axes against falling or dropping after switching off the motor power by, for example:
 - mechanically securing the vertical axes
 - adding an external braking/ arrester/ clamping mechanism
 - ensuring sufficient equilibration of the vertical axes
- The standard equipment motor brake or an external brake controlled directly by the drive controller are not sufficient to guarantee personal safety!

- ⇒ Disconnect electrical power to the equipment using a master switch and secure the switch against reconnection for:
 - maintenance and repair work
 - cleaning of equipment
 - long periods of discontinued equipment use
 - ⇒ Prevent the operation of high-frequency, remote control and radio equipment near electronics circuits and supply leads. If the use of such equipment cannot be avoided, verify the system and the installation for possible malfunctions in all possible positions of normal use before initial startup. If necessary, perform a special electromagnetic compatibility (EMC) test on the installation.
-

3.8 Protection Against Magnetic and Electromagnetic Fields During Operation and Mounting

Magnetic and electromagnetic fields generated near current-carrying conductors and permanent magnets in motors represent a serious health hazard to persons with heart pacemakers, metal implants and hearing aids.



WARNING

Health hazard for persons with heart pacemakers, metal implants and hearing aids in proximity to electrical equipment!

- ⇒ Persons with heart pacemakers, hearing aids and metal implants are not permitted to enter the following areas:
 - Areas in which electrical equipment and parts are mounted, being operated or started up.
 - Areas in which parts of motors with permanent magnets are being stored, operated, repaired or mounted.
 - ⇒ If it is necessary for a person with a heart pacemaker to enter such an area, then a doctor must be consulted prior to doing so. Heart pacemakers that are already implanted or will be implanted in the future, have a considerable variation in their electrical noise immunity. Therefore there are no rules with general validity.
 - ⇒ Persons with hearing aids, metal implants or metal pieces must consult a doctor before they enter the areas described above. Otherwise, health hazards will occur.
-

3.9 Protection Against Contact with Hot Parts



CAUTION

**Housing surfaces could be extremely hot!
Danger of injury! Danger of burns!**

- ⇒ Do not touch housing surfaces near sources of heat! Danger of burns!
 - ⇒ After switching the equipment off, wait at least ten (10) minutes to allow it to cool down before touching it.
 - ⇒ Do not touch hot parts of the equipment, such as housings with integrated heat sinks and resistors. Danger of burns!
-

3.10 Protection During Handling and Mounting

Under certain conditions, incorrect handling and mounting of parts and components may cause injuries.



CAUTION

Risk of injury by incorrect handling! Bodily harm caused by crushing, shearing, cutting and mechanical shock!

- ⇒ Observe general installation and safety instructions with regard to handling and mounting.
 - ⇒ Use appropriate mounting and transport equipment.
 - ⇒ Take precautions to avoid pinching and crushing.
 - ⇒ Use only appropriate tools. If specified by the product documentation, special tools must be used.
 - ⇒ Use lifting devices and tools correctly and safely.
 - ⇒ For safe protection wear appropriate protective clothing, e.g. safety glasses, safety shoes and safety gloves.
 - ⇒ Never stand under suspended loads.
 - ⇒ Clean up liquids from the floor immediately to prevent slipping.
-

3.11 Battery Safety

Batteries contain reactive chemicals in a solid housing. Inappropriate handling may result in injuries or material damage.



CAUTION

Risk of injury by incorrect handling!

- ⇒ Do not attempt to reactivate discharged batteries by heating or other methods (danger of explosion and cauterization).
- ⇒ Never charge non-chargeable batteries (danger of leakage and explosion).
- ⇒ Never throw batteries into a fire.
- ⇒ Do not dismantle batteries.
- ⇒ Do not damage electrical components installed in the equipment.

Note: Be aware of environmental protection and disposal! The batteries contained in the product should be considered as hazardous material for land, air and sea transport in the sense of the legal requirements (danger of explosion). Dispose batteries separately from other waste. Observe the legal requirements in the country of installation.

3.12 Protection Against Pressurized Systems

Certain motors and drive controllers, corresponding to the information in the respective Project Planning Manual, must be provided with pressurized media, such as compressed air, hydraulic oil, cooling fluid and cooling lubricant supplied by external systems. Incorrect handling of the supply and connections of pressurized systems can lead to injuries or accidents. In these cases, improper handling of external supply systems, supply lines or connections can cause injuries or material damage.



CAUTION

Danger of injury by incorrect handling of pressurized systems !

- ⇒ Do not attempt to disassemble, to open or to cut a pressurized system (danger of explosion).
- ⇒ Observe the operation instructions of the respective manufacturer.
- ⇒ Before disassembling pressurized systems, release pressure and drain off the fluid or gas.
- ⇒ Use suitable protective clothing (for example safety glasses, safety shoes and safety gloves)
- ⇒ Remove any fluid that has leaked out onto the floor immediately.

Note: Environmental protection and disposal! The media used in the operation of the pressurized system equipment may not be environmentally compatible. Media that are damaging the environment must be disposed separately from normal waste. Observe the legal requirements in the country of installation.

4 Type Code ADF

The type code describes the various motor options that can be delivered. It is the basis for ordering and pricing of products, spare parts and product services from REXROTH INDRAMAT. The general figures ("Type code column") of all ADF type codes are described in the following.

Notes:

- The individual type code for a particular motor size is a part of the respective chapter in this documentation.
 - Explanations on the use of individual options is contained in the chapter called "Application Guidelines".
-

4.1 Product

Type code column 1 2 3

ADF is the name of the product line of liquid-cooled asynchronous motors.

4.2 Motor Size

Type code column 4 5 6

The size of the motor is derived from the height of the shaft (distance of the middle of the shaft from base contact area). The size results from the assignment to the most obvious standard shaft height.

Available sizes: **ADF104/134/164/184**.

4.3 Length of Motor

Type code column 7

Within a product group, increasing length of motor is graded by ID letters in alphabetic order. Normally, an increase in motor length results in a higher continuous torque.

Lengths are, e.g., **B**, **C** and **D**.

4.4 Type

Type code column 9 10 11

ADF motors of the type **B05** (flange mounting) or type **B35** (foot mounting) can be delivered. The permissible mounting arrangements are explained in the chapter "Application Guidelines".

4.5 Position of the Power Connection

Type code column 12

Position of the power connection at the motor housing. Optionally to the left ("L"), at the top ("T") or to the right ("R"). The position of the power connection can not be changed after the motor has been manufactured.

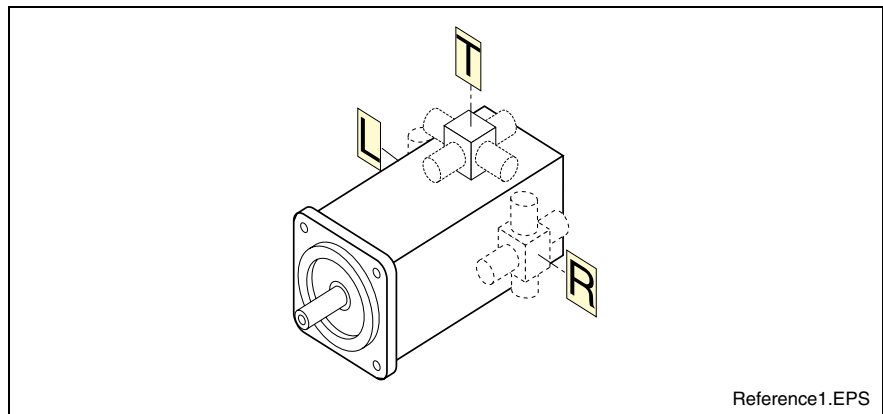

Reference1.EPS

Fig. 4-1: ADF Position of the Power Connection

4.6 Output Direction of Power Connection

Type code column 13

Possible output directions "A", "B", "L" and "R" of the power connection. The output direction of the flange box can not be changed after the motor has been manufactured.

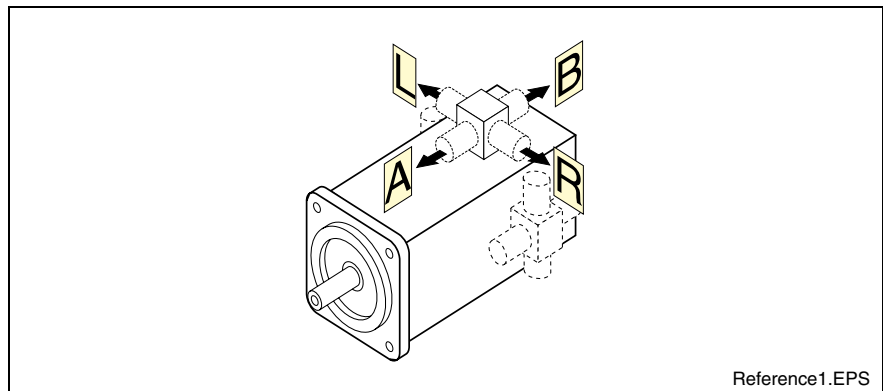

Reference1.EPS

Fig. 4-2: ADF Output Direction of the Power Connection



The "A side" is defined as the drive side and the "B side" as the non-drive side according to IEC34-7.

4.7 Coolant connection

Type code column 14

ADF motors must always be operated with a liquid cooling system. The connections are on the B side (non-drive side) of the motor.

4.8 Windings code

Type code column 16 17

Code for the type of winding. Winding code "•S" means a star connection. However, the drive combination is selected based on the respective selection data and operating characteristics.

4.9 Holding Brake

Type code column 18

Some ADF motors can be delivered with an integrated holding brake. Depending on the application, you select the holding brake either with an electrical lock or an electrical release.

Additional information is contained in the chapters "Technical Data ADF1•4" and "Application Guidelines".

4.10 Motor Feedback

Type code column 19

ADF motors can be delivered with integrated rotary encoders ("motor feedback").

Option	Type	Periods	Signal 1)	Interface
0	The motor is delivered from the factory without an encoder unit. The rear of the motor is closed with a lid.			
6	Incremental, single turn	512	1 V _{pp}	I ² C
7	Incremental, multiturn absolute	4096 x 512	1 V _{pp}	I ² C

1) All encoder signals are sinusoidal.

Fig. 4-3: ADF Motor Encoder

4.11 Drive Shaft

Type code column 21

To connect machine elements that are to be driven with the motor shaft, all ADF motors have the same options:

Drive Shaft			
	plain shaft	with keyway	
		with entire key balanced	with half of key balanced
without shaft seal ring	A	B	E
with shaft seal ring	C	D	H

Fig. 4-4: Options for the Drive Shaft

Motors with keyway are always delivered complete with keys.

There are centering drill holes with threads of type "DS" according to DIN 332, Sheet 2 in all motor shafts. Details are contained in the respective motor dimension sheet.

4.12 Shaft End Side B

Type code column 22

There is no option for a second shaft end for ADF motors.

4.13 Bearings

Type code column 23

The standard bearings (option "N") consists of deep-groove ball bearings for all ADF motors.

Reinforced bearings can be selected for handling larger radial forces (option "V", not for ADF104).

When the bearing has been reinforced, there is an additional cylinder roller bearing at the A side.

4.14 Vibration severity grade

Type code column 23

ADF motors are dynamically balanced corresponding to the requirements of DIN ISO 2373. The standard level is "R". Options "S" and "S1" can be selected for motors ADF134 and ADF164.

5 Technical Data ADF104

5.1 Data Sheet

Designation	Symbol	Unit	ADF104							
Motor Data ¹⁾										
Length			B	B	C	C	C	D		
Winding			BS	DS	AS	BS	CS	AS		
Rated torque	M_N	Nm	48	40	54	38	60	72		
Rated speed	n_N	min ⁻¹	2000	2200	2700	4200	1750	3000		
Rated power	P_N	kW	10	9.2	15.3	16.7	11	22.6		
Rated current	I_N	A	52	21.8	44	47.4	23.7	53.6		
Standstill continuous current	I_1	A	-	-	48	65.5	-	58.7		
Standstill continuous torque	M_1	Nm	-	-	60	60	-	81		
Derating speed	n_1	min ⁻¹	-	-	2000	2000	-	2000		
Min. cross-section of power connection ²⁾	A	mm ²	10	2.5	10	16	4	16		
Moment of inertia of rotor ³⁾	J_m	kgm ²	0.014		0.025			0.03		
Mass ³⁾	m	kg	56		70			88		
Maximum speed	n_{max}	min ⁻¹	9000							
Medium sound pressure ⁴⁾	L_p	dB(A)	in preparation							
Permissible ambient temperature	t	°C	0...40							
Insulation class acc. to DIN VDE 0530-1			F							
Class of protection			IP65							
Liquid cooling ⁵⁾										
Power loss	P_V	kW	1.8	2.3	3.2	3.3	2.1	3		
Coolant temperature	Coolant insertion point	ϑ_{in}	10...40							
	Permitted increase at P_V	$\Delta\vartheta_N$	10							
Pressure loss at Q_N	without quick coupling	Δp	in preparation							
	with quick coupling									
Required coolant throughput at P_V	Q_N	l/min	2.5	3.3	4.5	5	3.23	5		
Permissible starting pressure	p_{max}	bar	3							
Holding brake (optional)										
Transferable torque	M_4	Nm	not available							
Connection voltage	U_N	V								
Rated current	I_N	A								
Moment of inertia	J_m	kgm ²								
Maximum permissible brake energy	W_{max}	Ws								
Release delay	t_l	ms								
Lock delay	t_k	ms								
Mass	m	kg								
¹⁾ Values determined according to IEC 60034-1. Current and voltage values are indicated as root-mean-square value. Selection data and operating curves are contained in a separate documentation. ²⁾ Rated current-carrying capacity acc. to VDE0298-4 (1992) and laying method B2 acc. to EN60204-1 (1993) at 40 °C ambient temperature. ³⁾ Value without holding brake. ⁴⁾ At 1 m distance, with PWM = 4 kHz ⁵⁾ Data refers to coolant water. When using other coolant, convert data or take values from sytem flow diagram.										

Fig. 5-1: ADF104 Data Sheet

5.2 Type Code ADF104

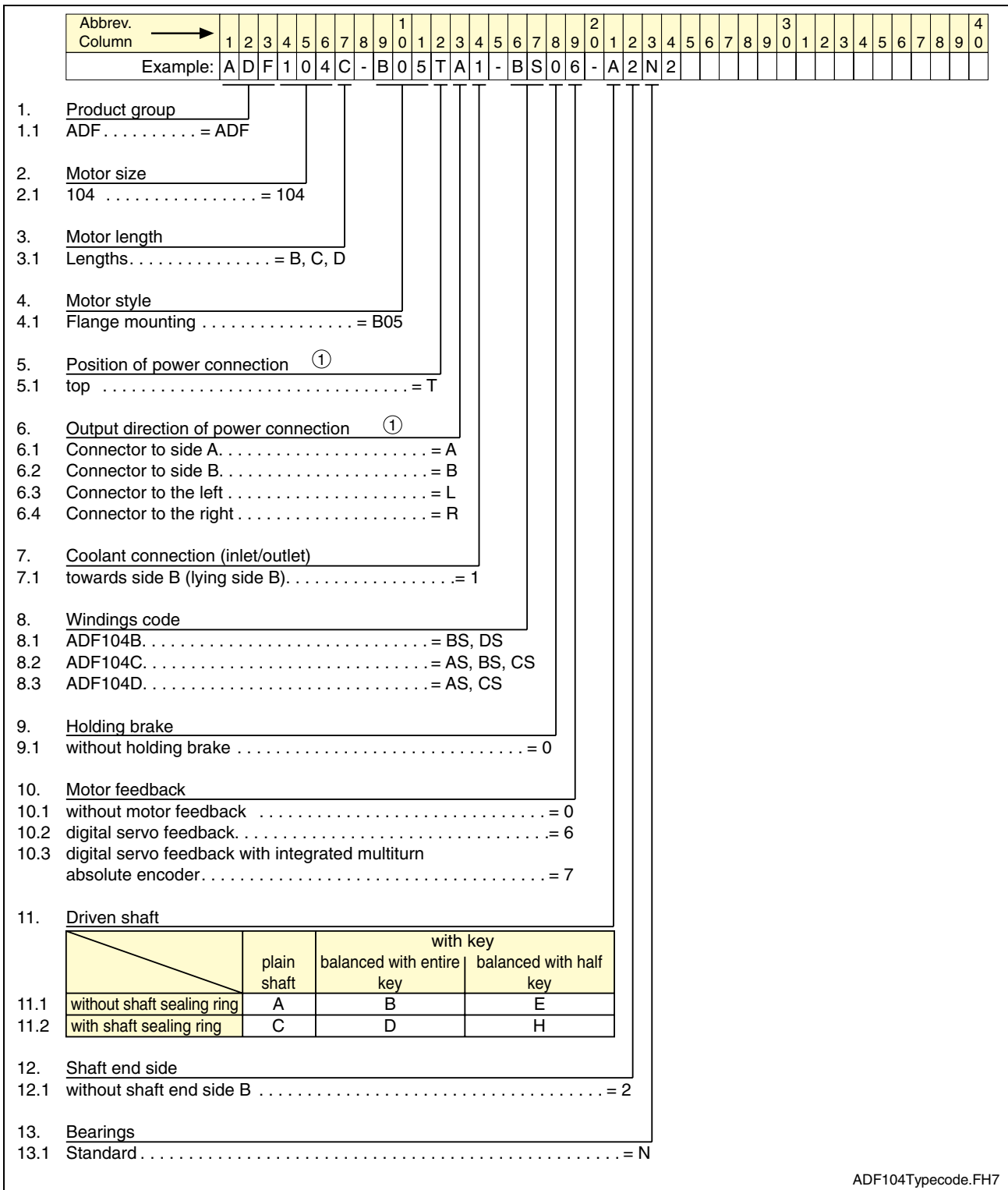

Fig. 5-2: ADF104 Type Code (1)

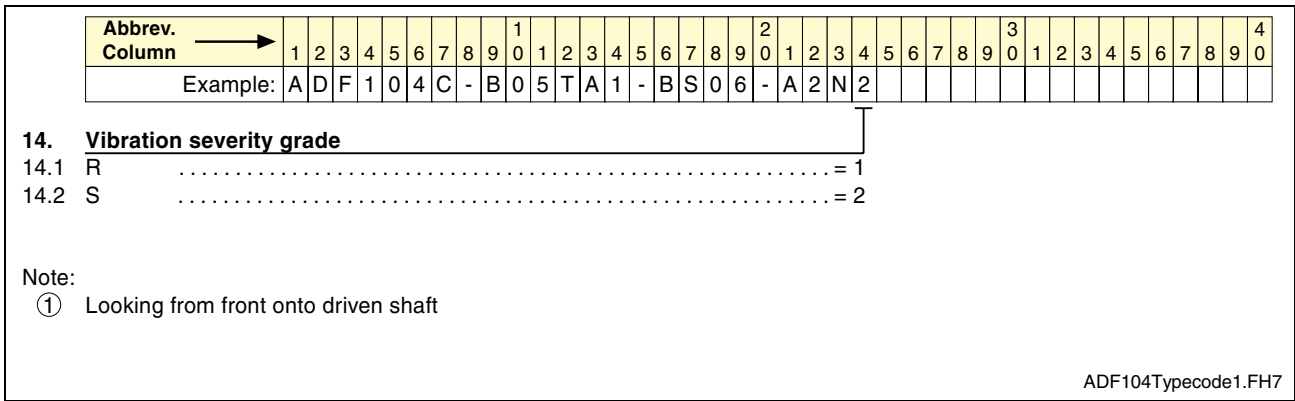

Fig. 5-3: ADF104 Type Code (2)

Note:

- Detailed explanations of individual options are contained in the chapter "Application Instructions".
- Check that the individual options are available before ordering from your Rexroth Indramat sales representative.

5.3 Dimensions Sheet ADF104

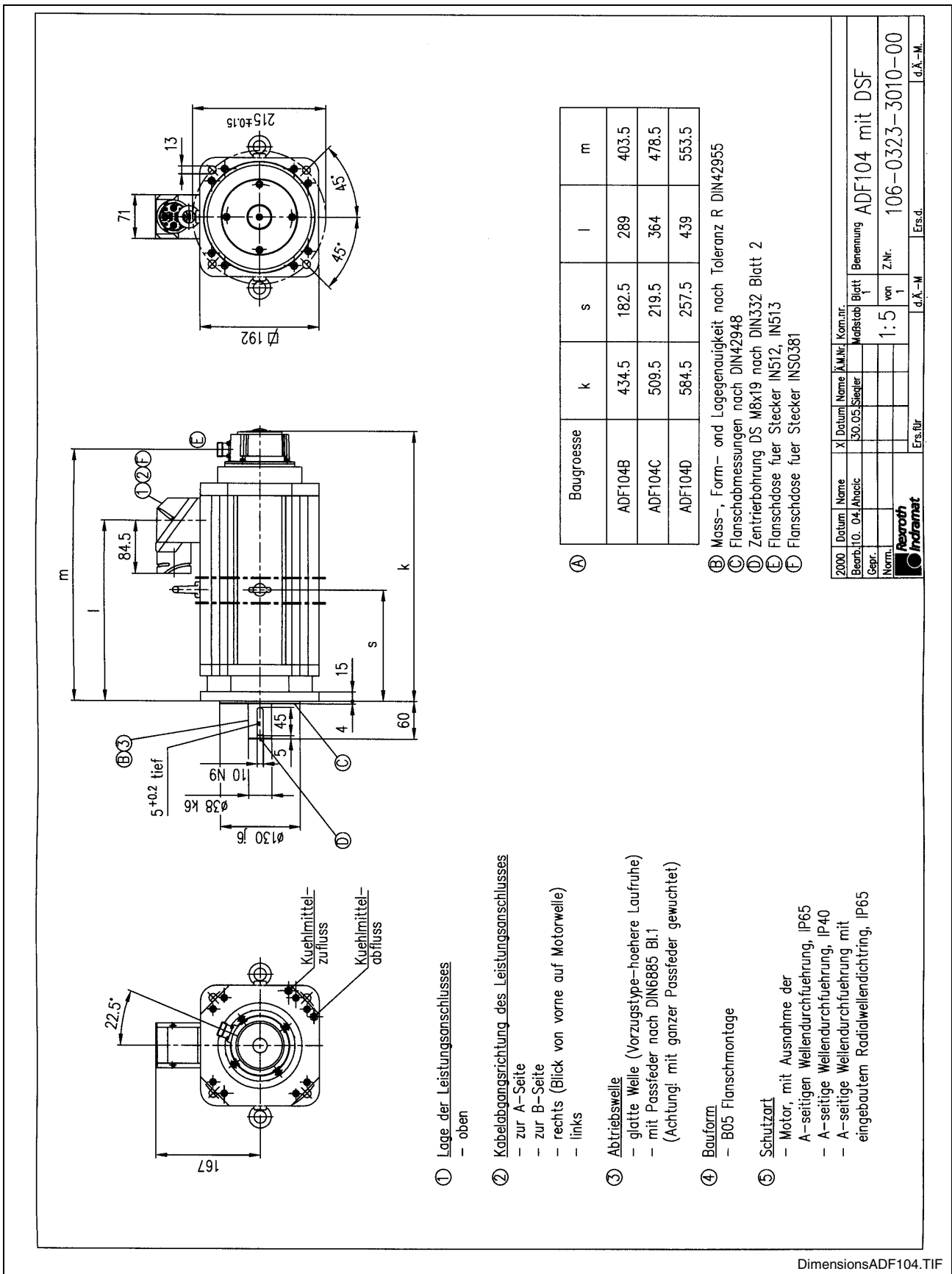
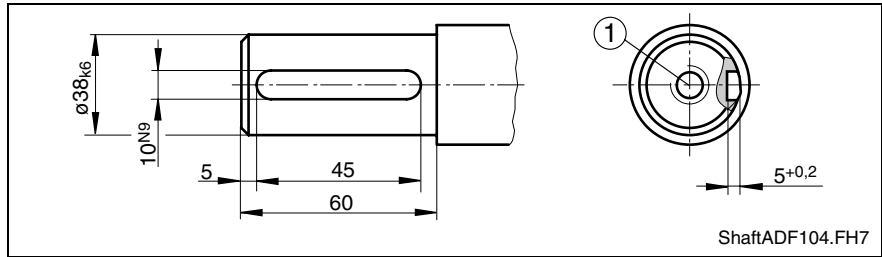

Fig. 5-4: ADF104 Dimensions Sheet

Drive Shaft with Keyway



- (1): Centering bore hole M8 x 19 acc. to DIN 332. True running tolerance R acc. to DIN 42955. Corresponding keys A10 x 8 x 45 acc. to DIN 6885 (included in delivery).

Fig. 5-5: ADF104 Drive Shaft with Keyway

5.4 Grease Life

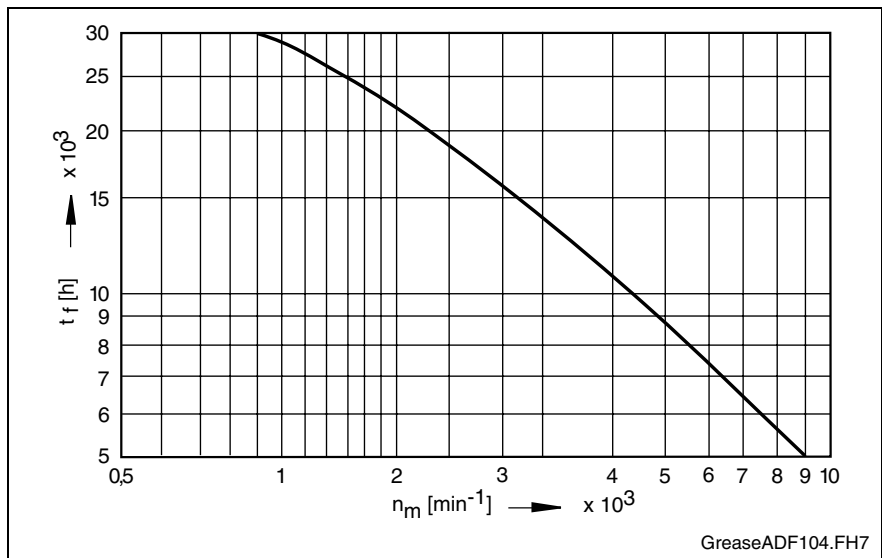

- t_f : grease life
- n_m : mean speed

Fig. 5-6: ADF104 Grease Life

Note: The grease life shown was determined under optimal operating conditions. Deviations to these conditions may influence the grease life.

5.5 Shaft Load

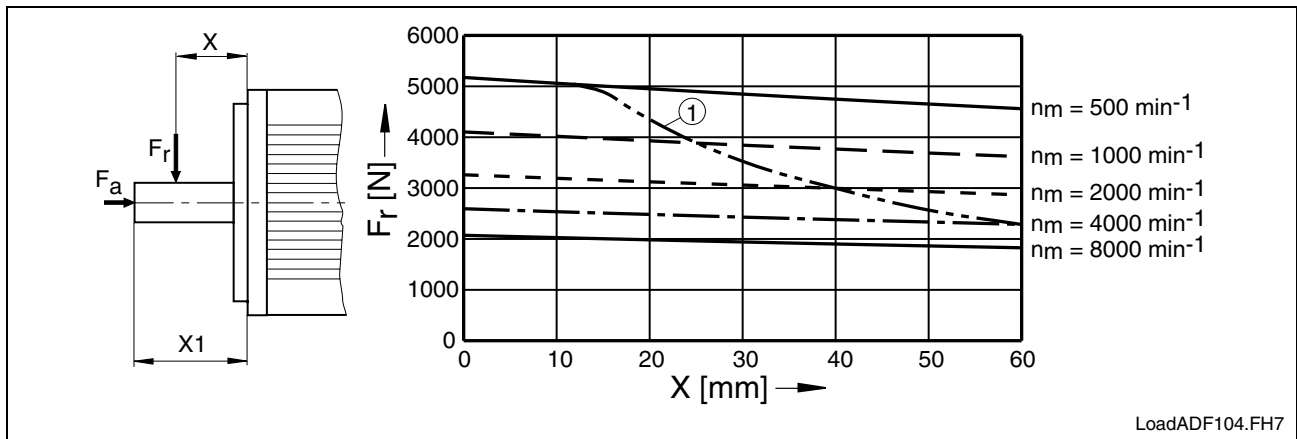

F_r : Permissible radial force at a mechanical life time $L_h = 20000$ operating hours.

F_a : Permissible axial force. Max. 30 N in all installation positions.

X : Distance between the attacking point of the radial force F_r and the motor flange.

X_1 : Permissible effective range of radial force F_r .

n_m : Mean speed

(1): Load limit for drive shaft with key

Fig. 5-7: ADF104: Shaft Load

6 Technical Data ADF134

6.1 Data Sheet

Designation	Symbol	Unit	ADF134					
Motor Data ¹⁾								
Length			B			C		D
Winding			BS			BS		BS
Rated torque	M_N	Nm	95			133		180
Rated speed	n_N	min^{-1}	2000			2000		2000
Rated power	P_N	kW	20			27.8		37.7
Rated current	I_N	A	50			62.1		89
Standstill continuous current	I_1	A						
Standstill torque	M_1	Nm						
Derating speed	n_1	min^{-1}						
Min. cross-section of power connection ²⁾	A	mm^2	10			16		25
Moment of inertia of rotor ³⁾	J_m	kgm^2	0.079			0.085		0.162
Mass ³⁾	m	kg	88			109		152
Maximum speed	n_{max}	min^{-1}	7500					
Medium sound pressure ⁴⁾	L_p	dB(A)	in preparation					
Permissible ambient temperature	t	$^{\circ}\text{C}$	0...40					
Insulation class acc. to DIN VDE 0530-1			F					
Class of protection			IP65					
Liquid cooling ⁵⁾								
Power loss	P_V	kW	2.4			3.1		3.4
Coolant temperature	Coolant insertion point	ϑ_{in}	$^{\circ}\text{C}$ 10...40					
	Permitted increase at P_V	$\Delta\vartheta_N$	K 10					
Pressure drop at Q_N	without quick coupling	Δp	0.6			0.9		1.2
	with quick coupling	Δp	1			1.5		2
Required coolant throughput at P_V	Q_N	l/min	3.5			4.5		5.5
Permissible starting pressure	p_{max}	bar	3					
Holding brake (optional)								
Transferable torque	M_4	Nm	not available					
Connection voltage	U_N	V						
Rated current	I_N	A						
Moment of inertia	J_m	kgm^2						
Maximum permissible brake energy	W_{max}	Ws						
Release delay	t_l	ms						
Lock delay	t_k	ms						
Mass	m	kg						
¹⁾ Values determined according to IEC 60034-1. Current and voltage values are indicated as root-mean-square value. Selection data and operating curves are contained in a separate documentation. ²⁾ Rated current-carrying capacity acc. to VDE0298-4 (1992) and laying method B2 acc. to EN60204-1 (1993) at 40 $^{\circ}\text{C}$ ambient temperature. ³⁾ Value without holding brake. ⁴⁾ At 1 m distance, with PWM = 4 kHz ⁵⁾ Data refers to coolant water. When using other coolant, convert data or take values from flow diagram.								

Fig. 6-1: ADF134 Data Sheet

6.2 Type Code ADF134

Abbrev. Column	1	2	3	4	5	6	7	8	9	0	1	2	3	4	5	6	7	8	9	0	1	2	3	4	5	6	7	8	9	0	1	2	3	4	5	6	7	8	9	0					
Example:	A	D	F	1	3	4	C	-	B	0	5	T	C	3	-	B	S	0	0	-	C	2	V	1																					

- 1. Product**
 - 1.1 ADF = ADF

- 2. Motor size**
 - 2.1 134 = 134

- 3. Motor length**
 - 3.1 Lengths = B, C, D

- 4. Mounting style**
 - 4.1 Flange mounting = B05^①
 - 4.2 Flange and foot mounting = B35

- 5. Position of power connection^②**
 - 5.1 left = L
 - 5.2 right = R
 - 5.3 top = T

- 6. Output direction of power connection^②**

	Power plug (Blower with plug)	Junction box (Blower w. junction box)
6.1 to side A	A	C
6.2 to side B	B	D
6.3 to the left	L	F
6.4 to the right	R	E

- 7. Coolant connection (inlet / outlet)**
 - 7.1 axial (to side B) with connection thread 1/4" = 0
 - 7.2 axial (to side B) with rapid action couplin = 3

- 8. Windings code**
 - 8.1 ADF134B = BS
 - 8.2 ADF134C = BS
 - 8.3 ADF134D = BS

- 9. Holding brake**
 - 9.1 without holding brake = 0
 - 9.2 with holding brake 100 Nm, electrical clamp = 1

- 10. Motor feedback**
 - 10.1 without motor feedback = 0
 - 10.2 digital servo feedback = 6
 - 10.3 digital servo feedback with integr. multiturn absolute encoder = 7

- 11. Driven shaft**

	plain shaft	with key	
		balanced with entire key	balanced with half key
11.1 without shaft sealing ring	A	B	E
11.2 with shaft sealing ring	C	D	H

Adf134Typecode1.FH7

Fig. 6-2: ADF134 Type Code (1)

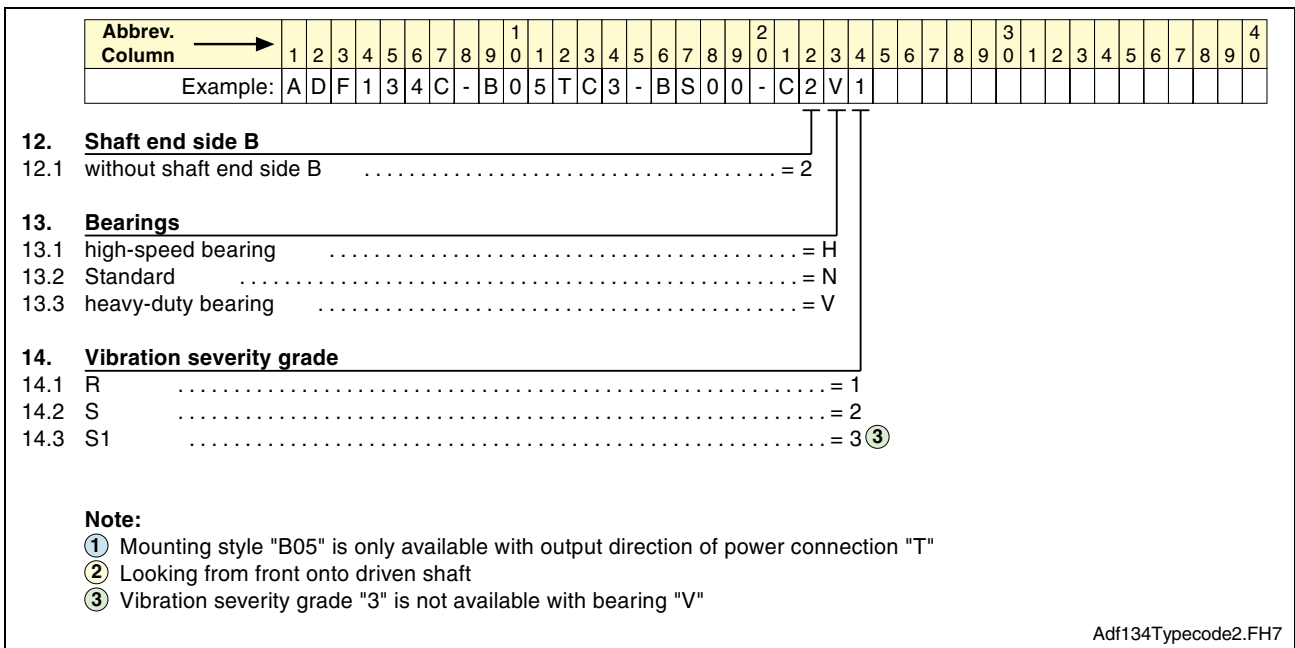

Fig. 6-3: ADF134 Type Code (2)

Note:

- Detailed explanations of individual options are contained in the chapter "Application Instructions".
- Check that the individual options are available before ordering from your Rexroth Indramat sales representative.

6.3 Dimensions Sheet ADF134 (Flange Socket)

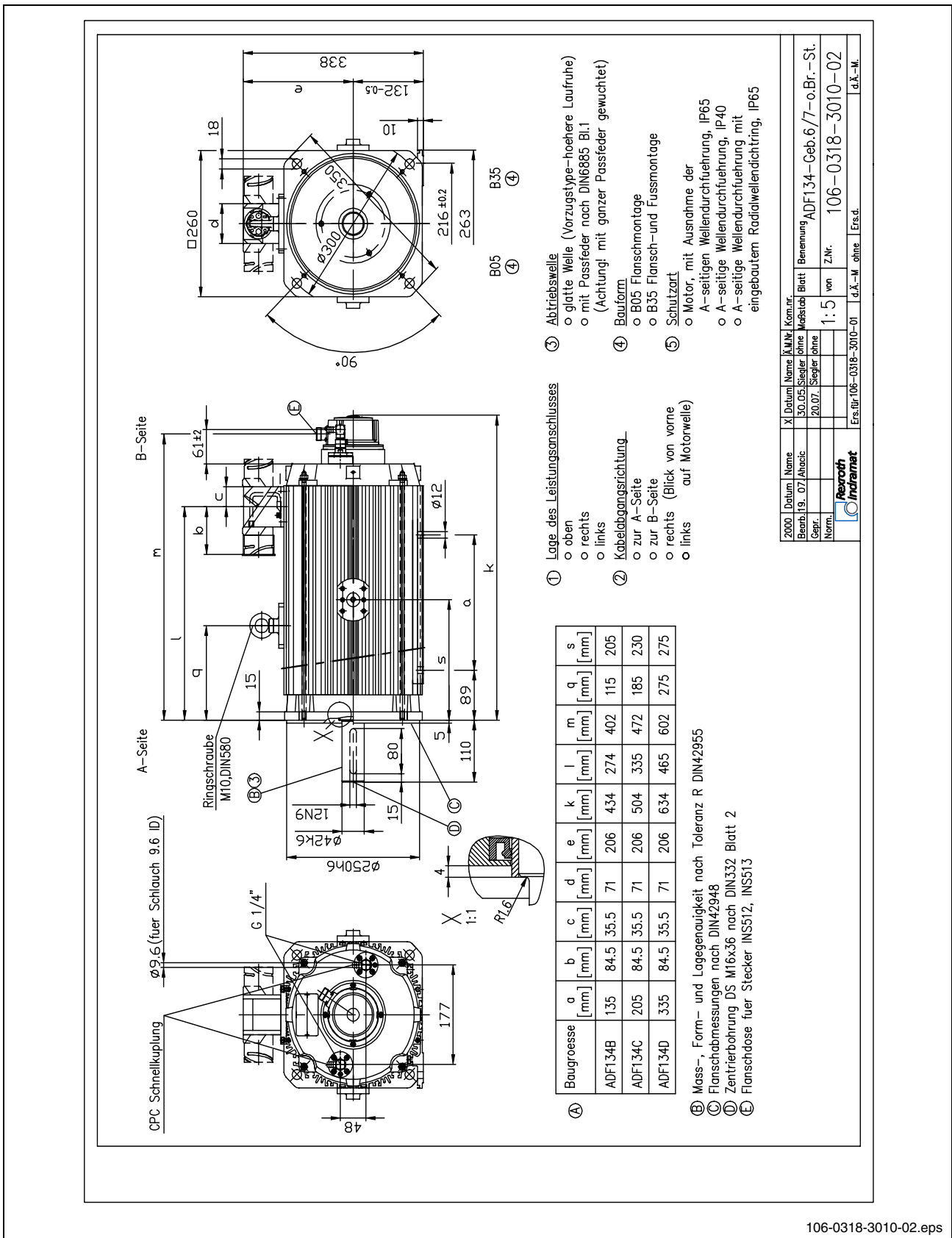
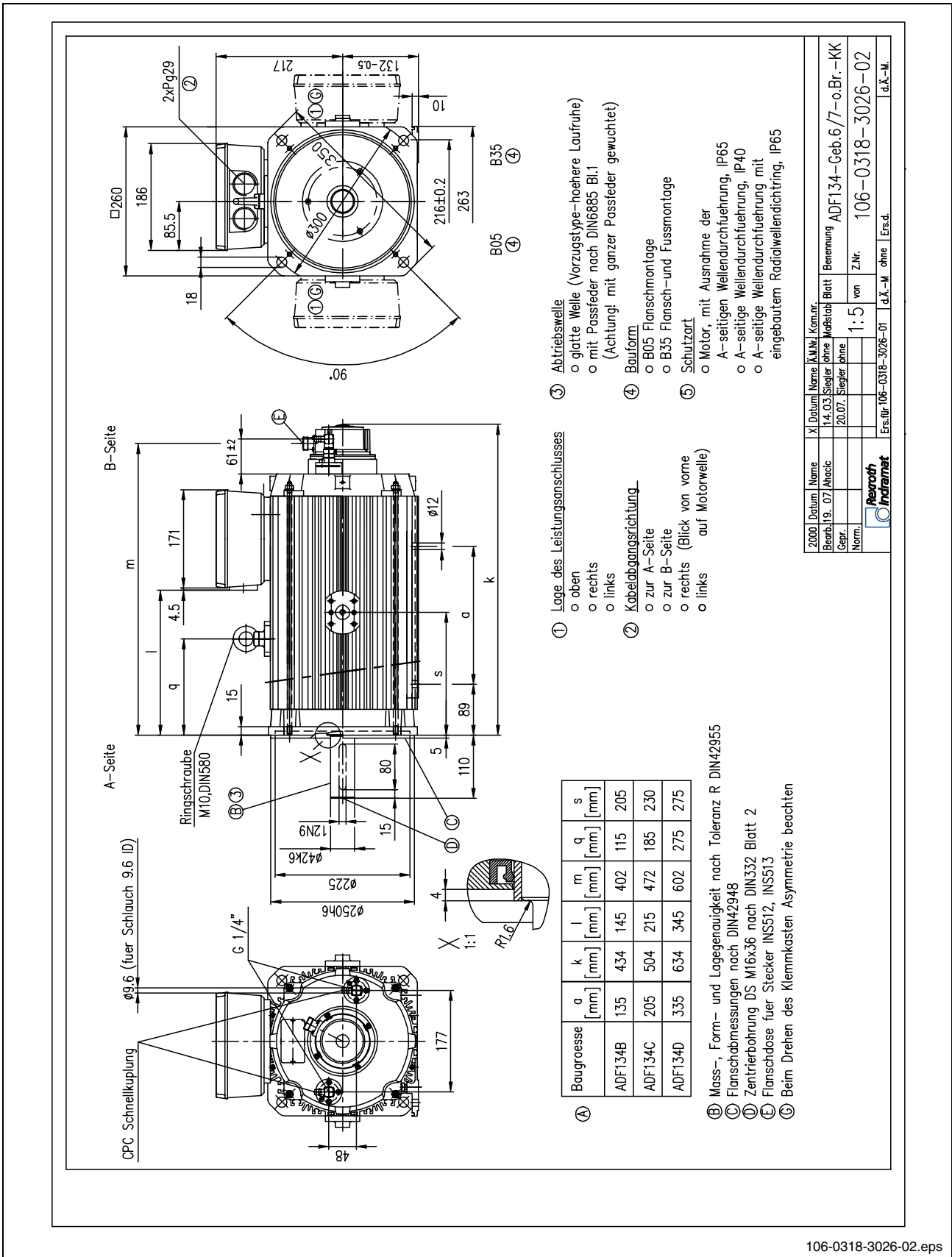

Fig. 6-4: ADF134 Dimensions Sheet (1)

6.5 Dimensions Sheet ADF134 (Terminal Box)



106-0318-3026-02.eps

Fig. 6-6: ADF134 Dimensions Sheet (3)

Drive Shaft with Keyway

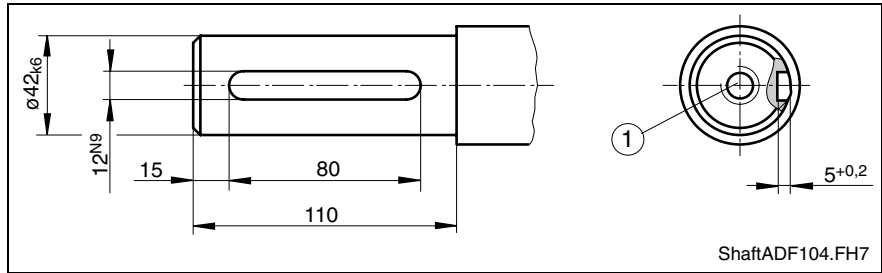

(1): Centering bore hole M16 x 36 acc. to DIN 332. True running tolerance R acc. to DIN 42955. Corresponding key A12 x 8 x 80 acc. to DIN 6885 (included in delivery).

Fig. 6-7: ADF134 Drive Shaft with Keyway

6.6 Grease Life

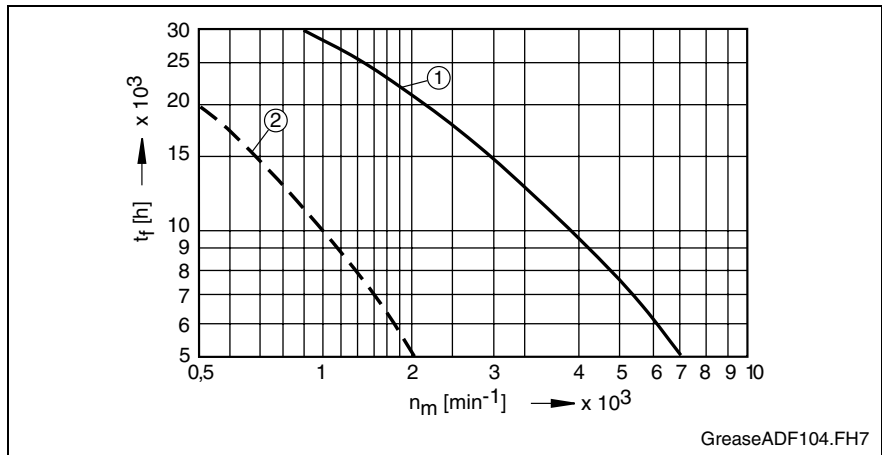

t_f : Grease Life
 n_m : Mean speed
 (1): Standard bearing
 (2): Reinforced bearing

Fig. 6-8: ADF134 Grease Life

Note: The grease life shown was determined under optimal operating conditions. Deviations to these conditions may influence the grease life.

6.7 Shaft Load

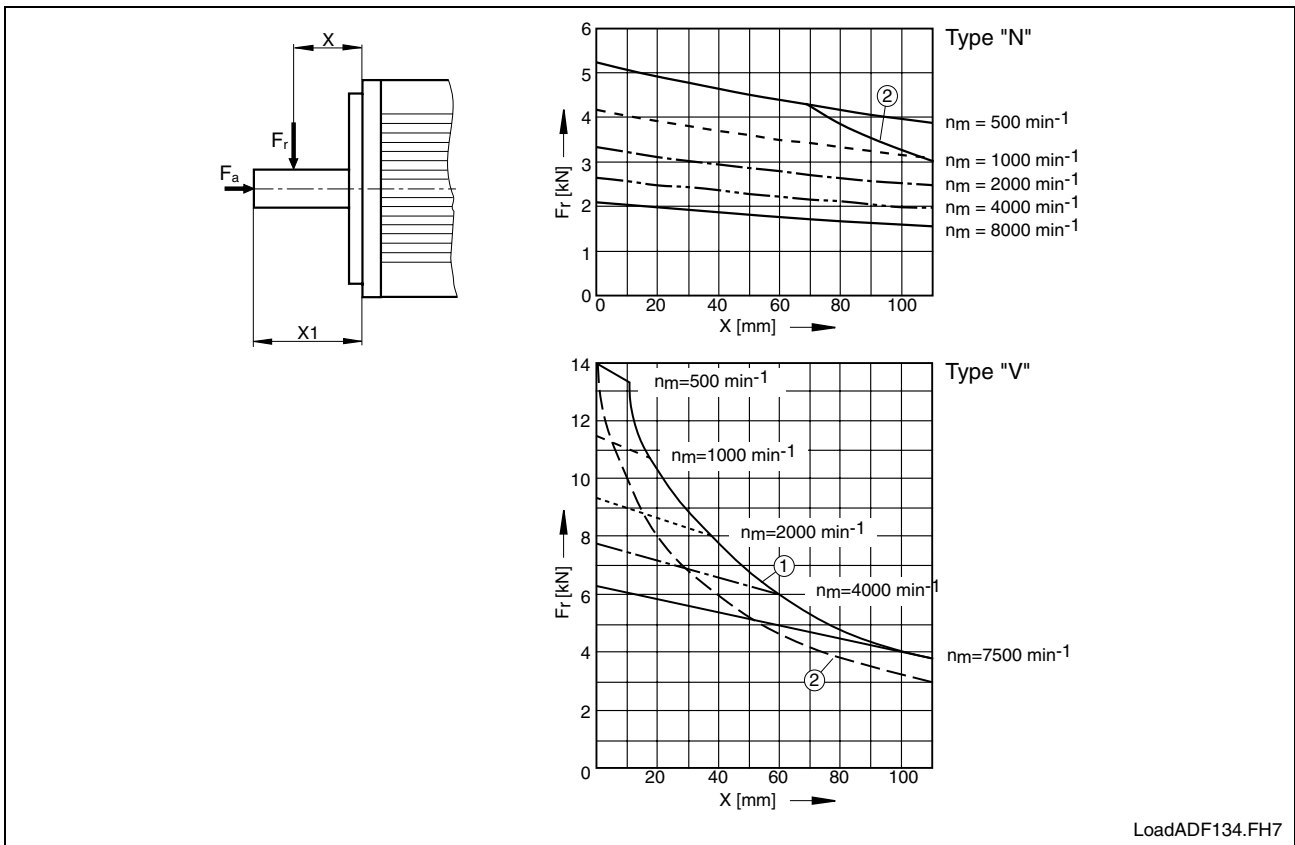

LoadADF134.FH7

- F_r : Permissible radial force at a mechanical life time $L_h = 20000$ operating hours.
- F_a : Permissible axial force. max. 30 N in all installation positions.
- X : Distance between the attacking point of the radial force F_r and the motor flange.
- X_1 : Permissible effective range of radial force F_r .
- n_m : Mean speed
- (1): Load limit for drive shaft with key
- (2): Load limit for drive shaft with key
- "N": Standard bearing
- "V": Reinforced bearing

Fig. 6-9: ADF134:Shaft Load

Note: ADF134 motors with reinforced bearing may only be operated with a minimum radial force of $F_r \geq 1$ kN.

7 Technical Data ADF164

7.1 Data Sheet

Designation	Symbol	Unit	ADF164					
Motor Data ¹⁾								
Length			B		C			
Winding			AS		AS			
Rated torque	M_N	Nm	262		334			
Rated speed	n_N	min^{-1}	2000		2000			
Rated power	P_N	kW	55		70			
Rated current	I_N	A	119		148			
Standstill continuous current	I_1	A	-		-			
Standstill continuous torque	M_1	Nm	-		-			
Derating speed	n_1	min^{-1}	-		-			
Min. cross-section of power connection ²⁾	A	mm^2	2x16		2x25			
Moment of inertia of rotor ³⁾	J_m	kgm^2	0.224		0.271			
Mass ³⁾	m	kg	197		228			
Maximum speed	n_{max}	min^{-1}	6000					
Medium sound pressure ⁴⁾	L_p	dB(A)	in preparation					
Permissible ambient temperature	t	$^{\circ}\text{C}$	0...40					
Insulation class acc. to DIN VDE 0530-1			F					
Class of protection			IP65					

Liquid cooling ⁵⁾								
Power loss	P_V	kW	5.2		6.8			
Coolant temperature	Coolant insertion point	ϑ_{in}	$^{\circ}\text{C}$ 10...40					
	Permitted increase at P_V	$\Delta\vartheta_N$	K 10					
Pressure loss at Q_N	without quick coupling	Δp	bar in preparation					
	with quick coupling	Δp	bar					
Required coolant throughput at P_V	Q_N	l/min	7.8		10			
Permissible starting pressure	p_{max}	bar	3					

Holding brake (optional)			elec. lock			elec. release		
Transferable torque	M_4	Nm	100			100		
Connection voltage	U_N	V	DC 24 \pm 10 %					
Rated current	I_N	A	1.8			2.0		
Moment of inertia	J_m	kgm^2	0.0065					
Maximum permissible brake energy	W_{max}	Ws	40000					
Release delay	t_l	ms	120			130		
Lock delay	t_k	ms	90			85		
Mass	m	kg	5					

¹⁾ Values determined according to IEC 60034-1. Current and voltage values are indicated as root-mean-square value. Selection data and operating curves are contained in the separate documentation.

²⁾ Rated current-carrying capacity acc. to VDE0298-4 (1992) and laying method B2 acc. to EN60204-1 (1993) at 40 $^{\circ}\text{C}$ ambient temperature.

³⁾ Value without holding brake.

⁴⁾ At 1 m distance, with PWM = 4 kHz

⁵⁾ Data refers to coolant water. When using other coolant, convert data or take values from flow diagram

Fig. 7-1: ADF164 Data Sheet

7.3 Dimensions Sheet ADF164 (Terminal Box)

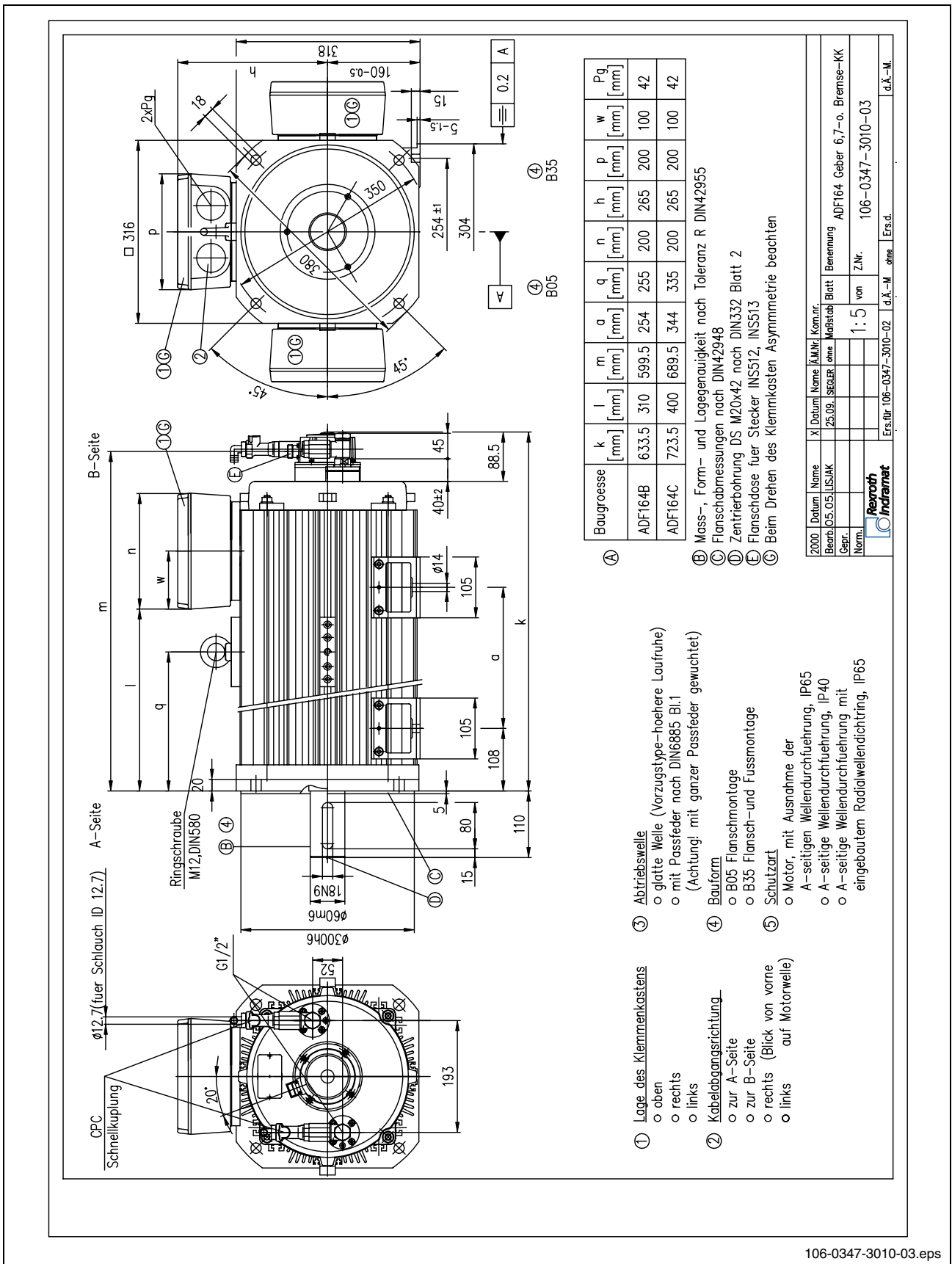
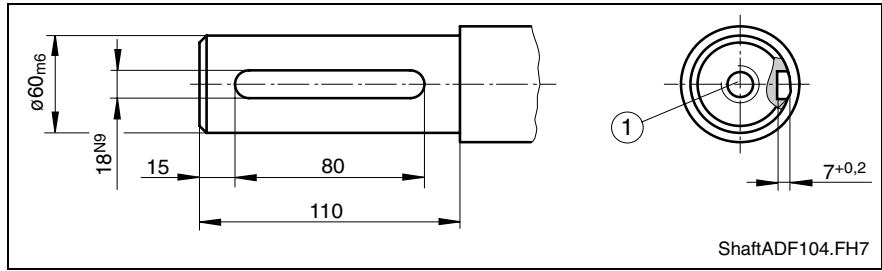

Fig. 7-4: Dimensions Sheet ADF164 (1)

Drive Shaft with Keyway



- (1): Centering borehole M20 x 42 DS acc. to DIN 332. True running tolerance R acc. to DIN 42955. Corresponding key A16 x 10 x 80 acc. to DIN 6885 (included in delivery).

Fig. 7-5: ADF164 Drive Shaft with Keyway

7.4 Grease Life

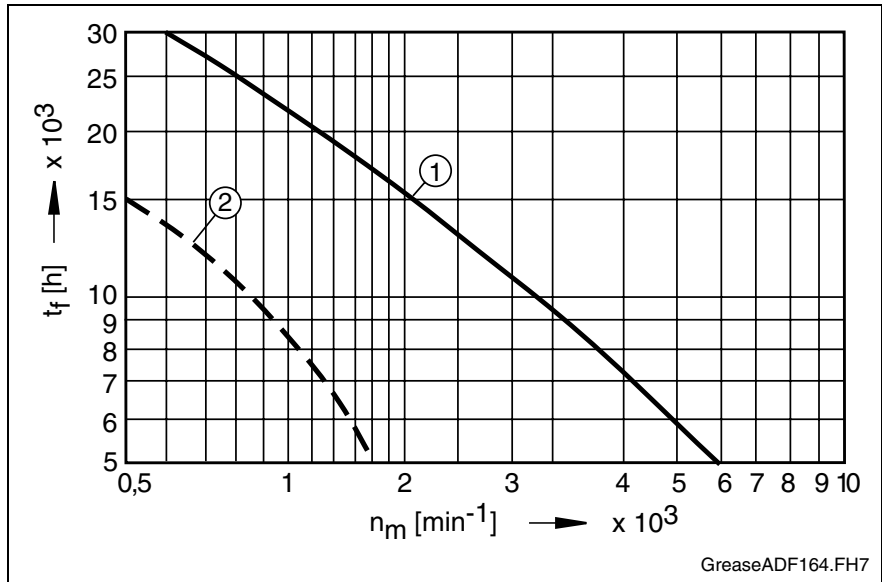

- t_f : Grease Life
 n_m : Mean speed
 (1): Standard bearing
 (2): Reinforced bearing

Fig. 7-6: ADF164 Grease Life

Note: The grease life shown was determined under optimal operating conditions. Deviations to these conditions may influence the grease life.

7.5 Shaft Load

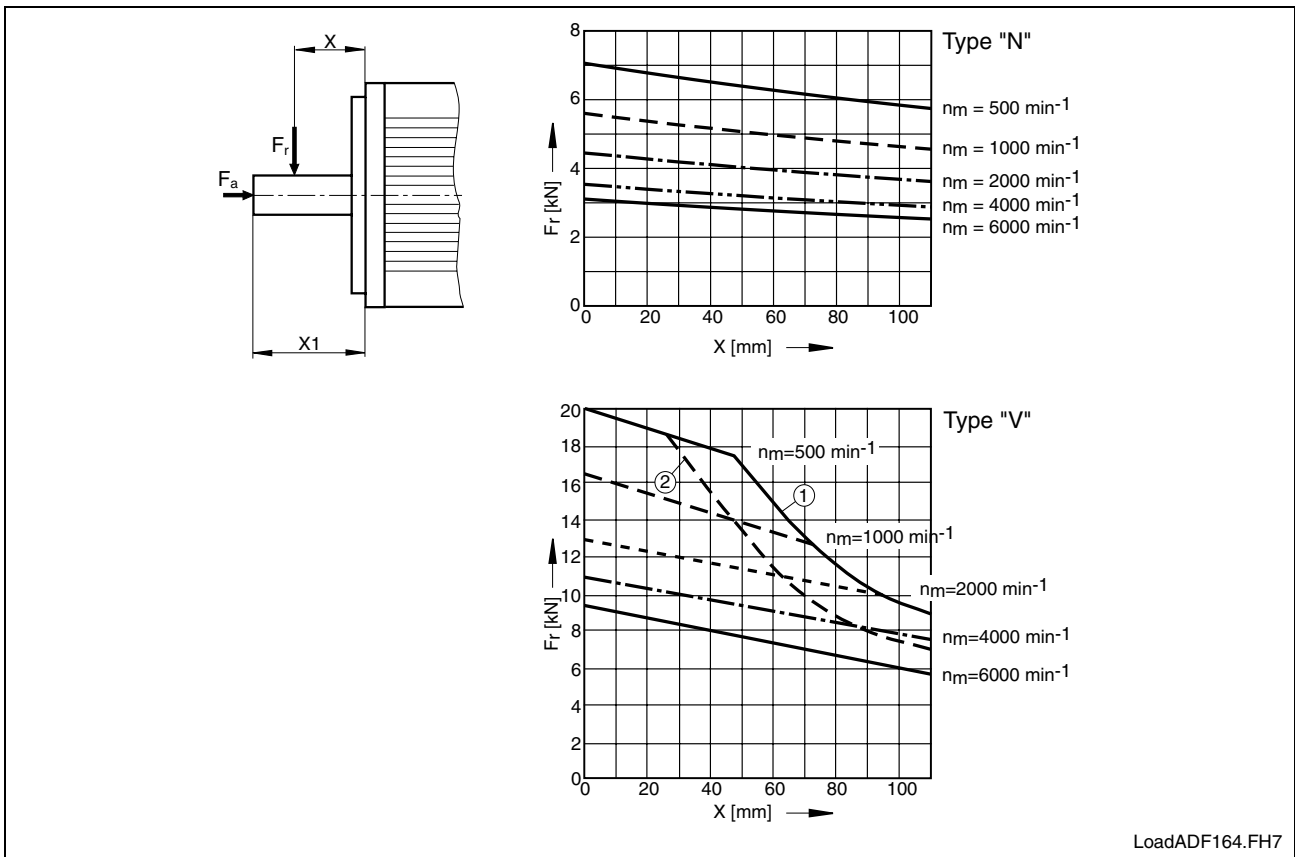

- F_r : Permissible radial force at a mechanical life time $L_h = 20000$ operating hours.
- F_a : Permissible axial force. max. 30 N in all installation positions.
- X : Distance between the attacking point of the radial force F_r and the motor flange.
- X_1 : Permissible effective range of radial force F_r .
- n_m : Mean speed
- (1): Load limit for drive shaft with keys
- (2): Load limit for drive shaft with keys
- "N": Standard bearing
- "V": Reinforced bearing

Fig. 7-7: ADF164 Shaft Load

Note: ADF164 motors with reinforced bearing may only be operated with a minimum radial force of $F_r \geq 1.5 \text{ kN}$.

8 Technical Data ADF184

8.1 Data Sheet

Designation	Symbol	Unit	ADF184		
Motor Data ¹⁾					
Length			C	D	
Winding			DS	DS	
Rated torque	M_N	Nm	320	390	
Rated speed	n_N	min ⁻¹	2000	2000	
Rated power	P_N	kW	67	81.7	
Rated current	I_N	A	154.3	162	
Standstill continuous current	I_1	A	-	-	
Standstill continuous torque	M_1	Nm	-	-	
Derating speed	n_1	min ⁻¹	-	-	
Min. cross-section of power connection ²⁾	A	mm ²	2 x 25	2 x 25	
Moment of inertia of rotor ³⁾	J_m	kgm ²	0.49	i.V.	
Mass ³⁾	m	kg	312	470	
Maximum speed	n_{max}	min ⁻¹	5400	5400	
Medium sound pressure ⁴⁾	L_p	dB(A)	in preparation		
Permissible ambient temperature	t	°C	0...40		
Insulation class acc. to DIN VDE 0530-1			F		
Class of protection			IP65		
Liquid cooling ⁵⁾					
Power loss	P_V	kW	5.4	6.1	
Coolant temperature	Coolant insertion point	ϑ_{in}	10...40		
	Permissible increase at P_{VN}	$\Delta\vartheta_N$	10		
Pressure loss at Q_N	without quick coupling	Δp	0.3	0.35	
	with quick coupling	Δp	0.4	0.45	
Required coolant throughput at P_V	Q_N	l/min	7.9	8.7	
Permissible starting pressure	p_{max}	bar	3		
Holding brake (optional)					
Transferable torque	M_4	Nm	not available		
Connection voltage	U_N	V			
Rated current	I_N	A			
Moment of inertia	J_m	kgm ²			
Maximum permissible brake energy	W_{max}	Ws			
Release delay	t_l	ms			
Lock delay	t_k	ms			
Mass	m	kg			
¹⁾ Values determined according to IEC 60034-1. Current and voltage values are indicated as root-mean-square value. Selection data and operating curves are contained in the separate documentation. ²⁾ Rated current-carrying capacity acc. to VDE0298-4 (1992) and laying method B2 acc. to EN60204-1 (1993) at 40 °C ambient temperature. ³⁾ Value without holding brake. ⁴⁾ At 1 m distance, with PWM = 4 kHz ⁵⁾ Data refers to coolant water. When using other coolant, convert data or take values from flow diagram					

Fig. 8-1: ADF184 Data Sheet

8.2 Type Code ADF184

Abbrev. Column →	1	2	3	4	5	6	7	8	9	0	1	2	3	4	5	6	7	8	9	0	2	0	1	2	3	4	5	6	7	8	9	0	3	0	1	2	3	4	5	6	7	8	9	0	4										
Example:	A	D	F	1	8	4	C	-	B	3	5	T	C	3	-	D	S	0	6	-	A	2	N	1																															

- 1. Product group**
 - 1.1 ADF = ADF
- 2. Motor size**
 - 2.1 184 = 184
- 3. Motor length**
 - 3.1 Lengths = C, D
- 4. Motor style**
 - 4.1 Flange and foot mounting = B35
- 5. Position of power connection ^①**
 - 5.1 left = L
 - 5.2 right = R
 - 5.3 top = T
- 6. Output direction of power connection ^①**
 - 6.1 Junction box connection to side A = C
 - 6.2 Junction box connection to side B = D
 - 6.3 Junction box connection to the left = E
 - 6.4 Junction box connection to the right = F
- 7. Coolant connection (inlet / outlet)**
 - 7.1 axial (to side B) with connection thread 1/2"..... = 0
 - 7.2 axial (to side B) with quick coupling = 3
- 8. Windings code**
 - 8.1 ADF184C = DS
 - 8.2 ADF184D = DS
- 9. Holding brake**
 - 9.1 without holding brake = 0
- 10. Motor feedback**
 - 10.1 digital servo feedback = 6
 - 10.2 digital servo feedback with integrated multturn absolute encoder = 7
- 11. Driven shaft**

		with key	
		balanced with entire key	balanced with half key
11.1	without shaft sealing ring	A	E
11.2	with shaft sealing ring	C	H
- 12. Shaft end side B**
 - 12.1 without shaft end side B = 2

ADF184Typecode1.FH7

Fig. 8-2: ADF184 Type Code (1)

8.3 Dimensions Sheet ADF184 (Terminal Box)

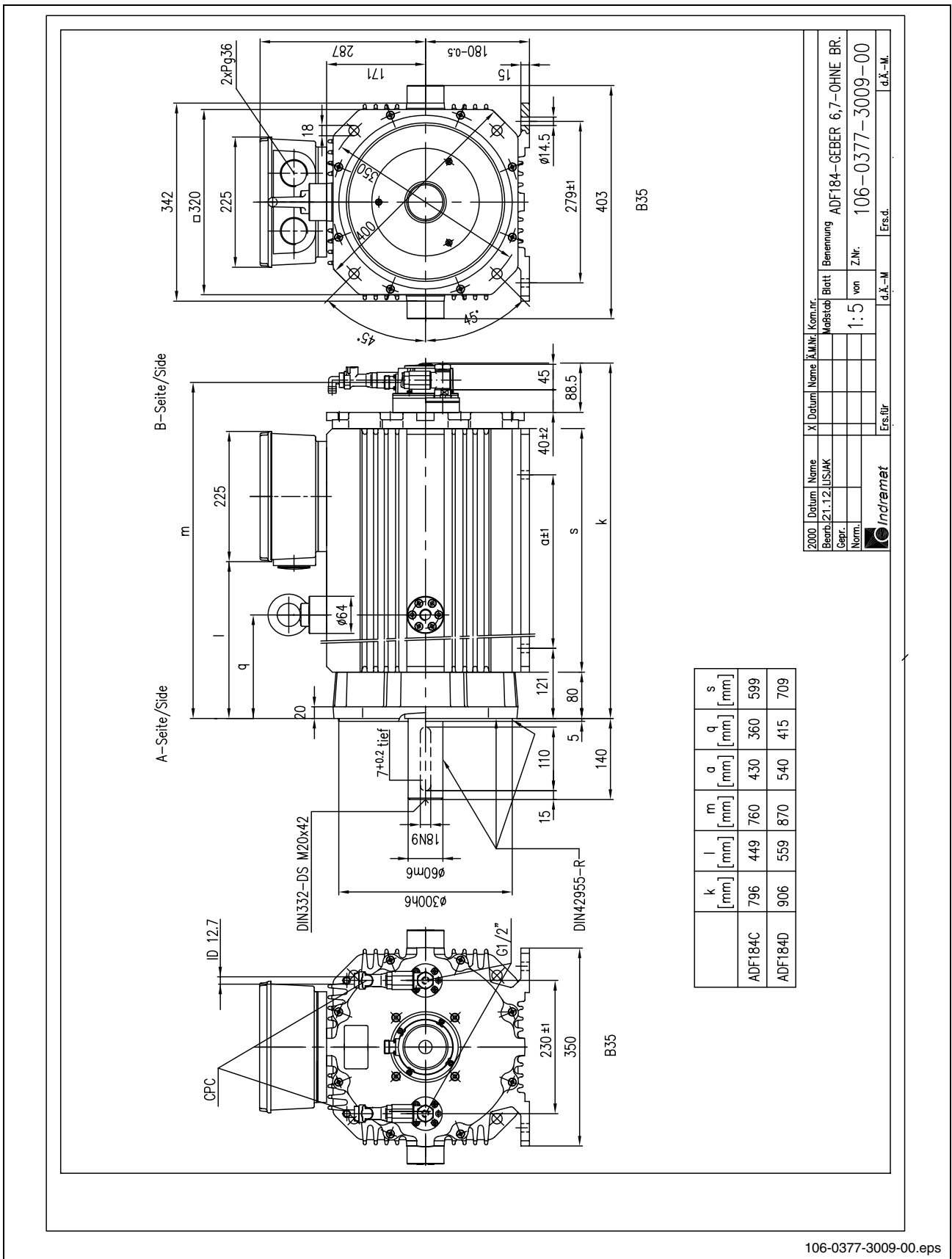

106-0377-3009-00.eps

Fig. 8-4: ADF184 Dimensions Sheet

Drive Shaft with Keyway

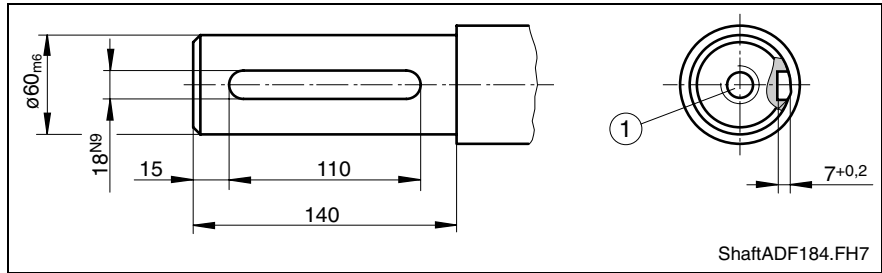

- (1): Centering borehole M20 x 42 DS acc. to DIN 332. True running tolerance R acc. to DIN 42955. Corresponding key A18 x 11 x 110 acc. to DIN 6885 (included in delivery).

Fig. 8-5: ADF184 Drive Shaft with Key

8.4 Grease Life

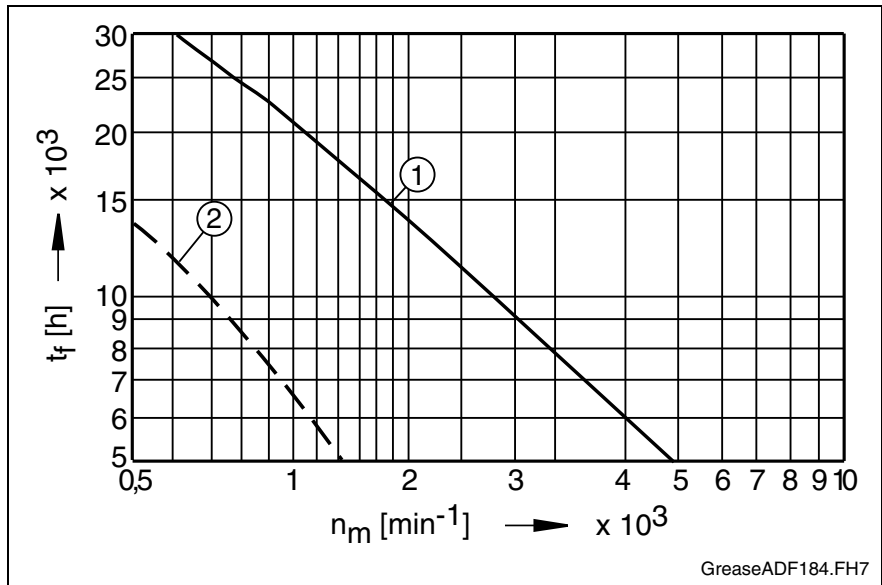

- t_f : Grease Life
- n_m : Mean speed
- (1): Standard bearing
- (2): Reinforced bearing

Fig. 8-6: ADF184 Grease Life

Note: The grease life shown was determined under optimal operating conditions. Deviations to these conditions may influence the grease life.

8.5 Shaft Load

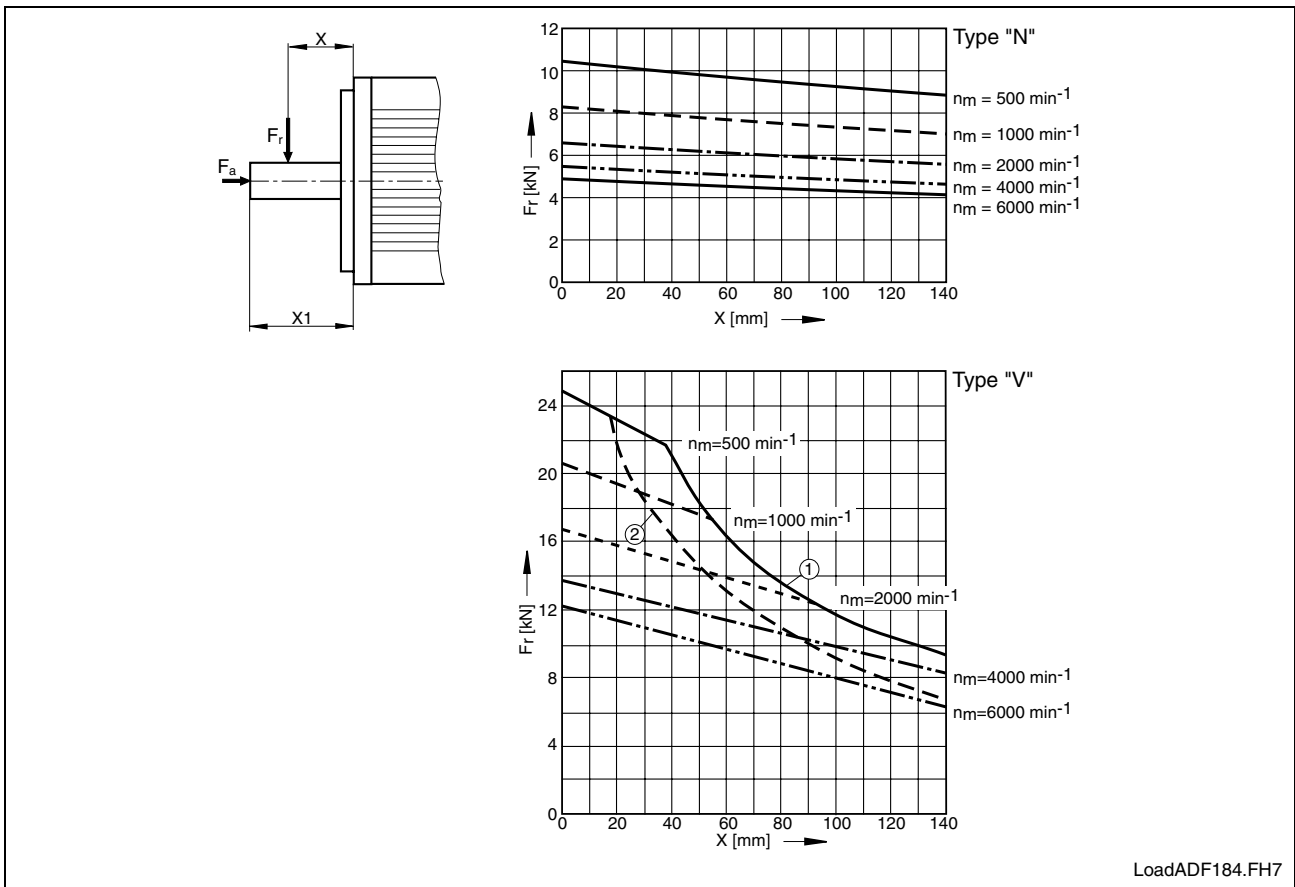

- F_r : Permissible radial force at a mechanical life time $L_h = 20000$ operating hours.
- F_a : Permissible axial force. max. 30 N in all installation positions.
- X : Distance between the attacking point of the radial force F_r and the motor flange.
- $X1$: Permissible effective range of radial force F_r .
- n_m : Mean speed
- (1): Load limit for drive shaft with key
- (2): Load limit for drive shaft with key
- "N": Standard bearing
- "V": Reinforced bearing

Fig. 8-7: ADF184 Shaft Load

Note: ADF184 motors with reinforced bearing may only be operated with a minimum radial force of $F_r \geq 2 \text{ kN}$.

9 Accessories

9.1 Labyrinth Seal

To protect against splashing liquid at the motor drive shaft, ADF motors already equipped with the "shaft sealing" option can be additionally equipped with labyrinth seals (accessory kit SUP-M02-2AD...).

Labyrinth Seal for	Accessory kit	Material Number
ADF132, ADF134	SUP-M02-2AD132	00273268
ADF160, ADF 164	SUP-M02-2AD160	00272843

Fig. 9-1: Accessory kit SUP-M02-2AD

The SUP-M02-2AD... accessory kit is delivered complete with fixing screws and assembly instructions.

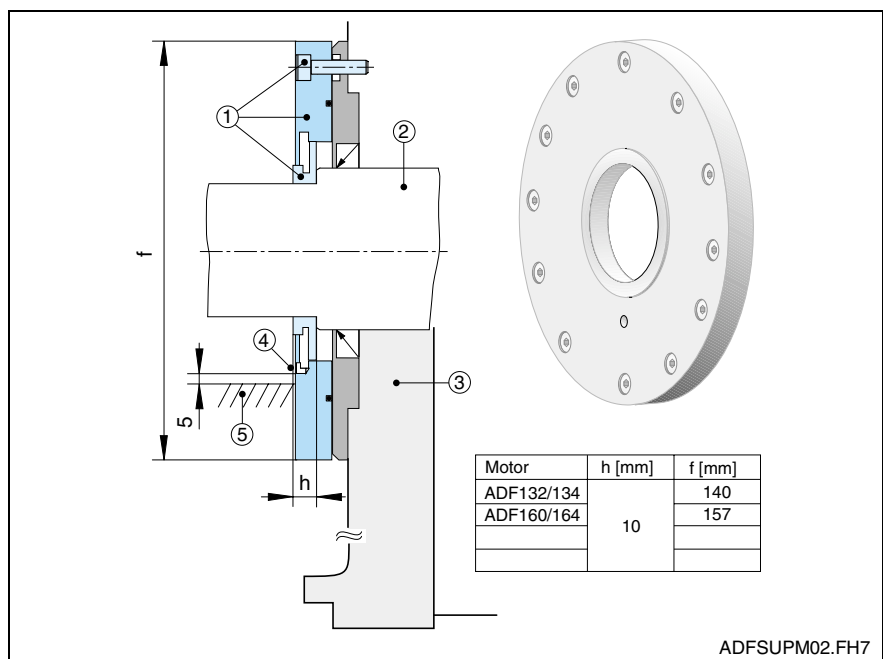

- (1): Labyrinth seal with fixing screws (included in delivery)
 (2): A-sided motor shaft
 (3): A-sided motor flange
 (4): Run-out borehole
 (5): Max. permitted level of liquid
 h: Height of labyrinth seal

Fig. 9-2: ADF Labyrinth Seal

Note:

- Observe the assembly instructions for the SUP-M02-2AD... accessories (included in delivery).
- The labyrinth seal is only effective from approx. 200 min⁻¹ and may only be mounted on motors where the shaft sealing has been mounted at the factory.
- Liquids entering into it can cause damage to the motor. The tightness of the motors is only guaranteed according to the specifications for the respective protective system of the motor.

10 Connections

10.1 Notes

The user can choose between ready-made cables from REXROTH INDRAMAT or he can assemble the required cables himself.

REXROTH INDRAMAT provides a comprehensive range of assembled cables, plugs and sockets that have been optimally adapted to the products and to the most varied requirements.

The decisive advantages of ready-made cables from REXROTH INDRAMAT are:

- Cable is completely ready for connection without any further work being required
- Cable is designed to withstand strain from continuous bending
- Resistance against mineral oils, grease and bio oils, hydrolysis-proof, free of silicon and halogen, low adhesion
- Certification acc. to UL and CSA
- Burning characteristics fulfil requirements of VDE0472-804
- Observes the EMC regulations
- Protective class up to IP67

Note: Please observe that self-assembled cable or cable systems from other manufacturers may not meet these requirements under certain conditions.

Rexroth Indramat does not accept any responsibility for faults or damages arising from this.



Additional information is available ...

- on **selection** of power cable and encoder cable for ADF motors in the documentation "Connection Cable for DIAX04, ECODRIVE03 and POWERDRIVE, Selection Data", Mat.No. 00280894.
- on **assembling** of cables and plugs as well as technical data in the documentation "Indramat Connection Technology, Assembly and Tools...", Mat.No. 00280895.
- on **dimensioning** of cooling systems for ADF motors in the documentation "Liquid Cooling of Indramat Drive Components", Mat.No. 00265836.

10.2 Power Connection

ADF motor power is connected via flange socket INS0380 or terminal box (ADF184 only terminal box). This must be chosen during product selection.

Note:

- When using the flange socket type, observe the following:
The motor side of the power cable must be equipped with a plug with a bayonet fixing.
- When using the "terminal box" type, observe the following:
The connection cable must be equipped at the motor end with wire ends or circular cable lugs.
- The power cable type depends also on the drive controller used. Observe the documentation on the drive controller.
- Plugs and cables are not included in the delivery of the motor. Plugs and cables must be ordered separately.

Survey

Motor		Flange socket 1)	Terminal Boxes 2)			
ADF	Winding		U-V-W	Ø	Ø PE	PG 3)
ADF104B	BS	INS380	AEH	Terminal strip Connection cross-section see data sheet	M6	29
ADF104B	DS	INS380	AEH		M6	29
ADF104C	AS	INS380	AEH		M6	29
ADF104C	BS	INS380	AEH		M6	29
ADF104C	CS	INS380	AEH		M6	29
ADF104D	AS	INS380	AEH		M6	29
ADF134B	BS	INS380	RKS	M8	M8	29
ADF134C	BS	INS380	RKS	M8	M8	29
ADF134D	BS	INS380	RKS	M8	M8	29
ADF164B	AS	INS380	RKS	M8	M8	42
ADF164C	AS	INS380	RKS	M8	M8	42
ADF184C	DS	-	AEH	terminal	2 x M12	2 x 36
ADF184D	DS	-	AEH	strip	2 x M12	2 x 36

1) Flange socket INS380: corresponding plug INS381
 2) AEH = wire ends for terminal strip. RKS = circular cable lugs for bolts.
 M6/8/10/12 = diameter of the connection bolts.
 3) PG threaded joints integrated into assembled power cables IKG.

Fig. 10-1: ADF Power Connections

Specialities of ADF184

Due to the connection cross-section required, the following specialities apply to the ADF184:

- ADF184 are only available in the "terminal box" model.
- For the power connection, 2 identical power cables are required with PG threaded joints and wire ends at the motor end.
- The connection terminals in the terminal box are in pairs (arrangement UU-VV-WW).
- There are two sets of connection screws for PE (green-yellow). Both must be connected to a PE wire with a circular cable lug.

10.3 ADF with Power Flange Socket

The connections shown in the following are required for operating an ADF motor with flange box.

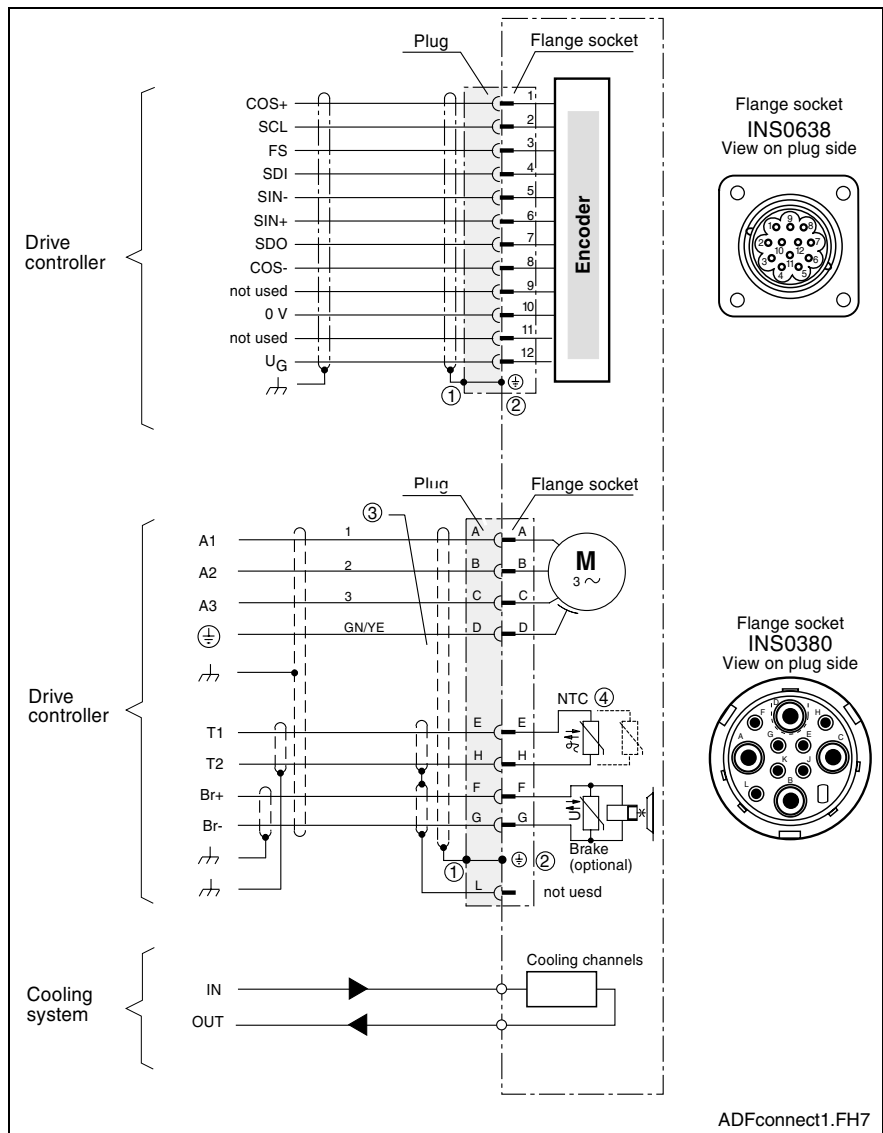

- (1) Shielded connection via cable strain relief in the plug.
- (2): Electrically conductive connection to the motor housing
- (3): Minimum cross-section of power cable and plug; refer to motor data sheet and Fig. 10-1 "Power connections".
- (4): Only one NTC sensor is connected. Spare connections for the replacement sensor are inside the plug housing.

Fig. 10-2: ADF with Flange Box, Outline

Flange Socket

The power plugs for connecting to the ADF motors with flange socket are equipped with a bayonet joint.

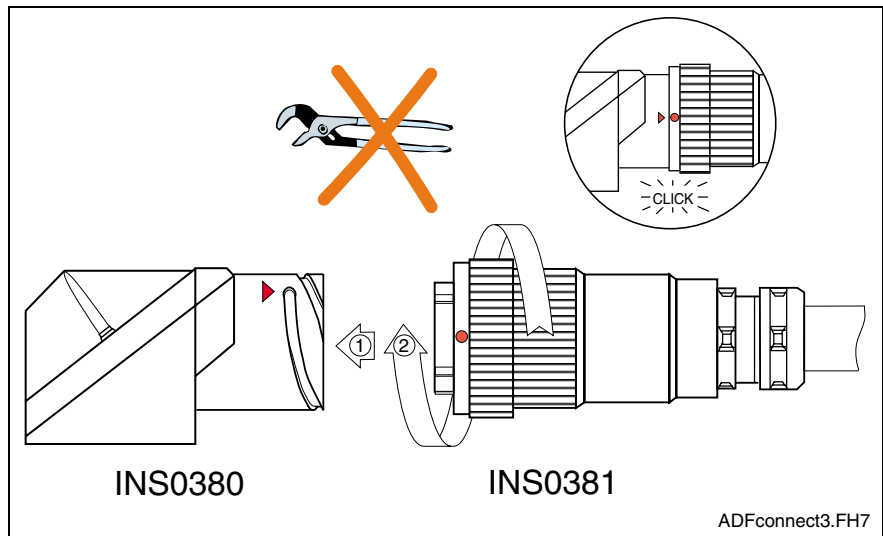
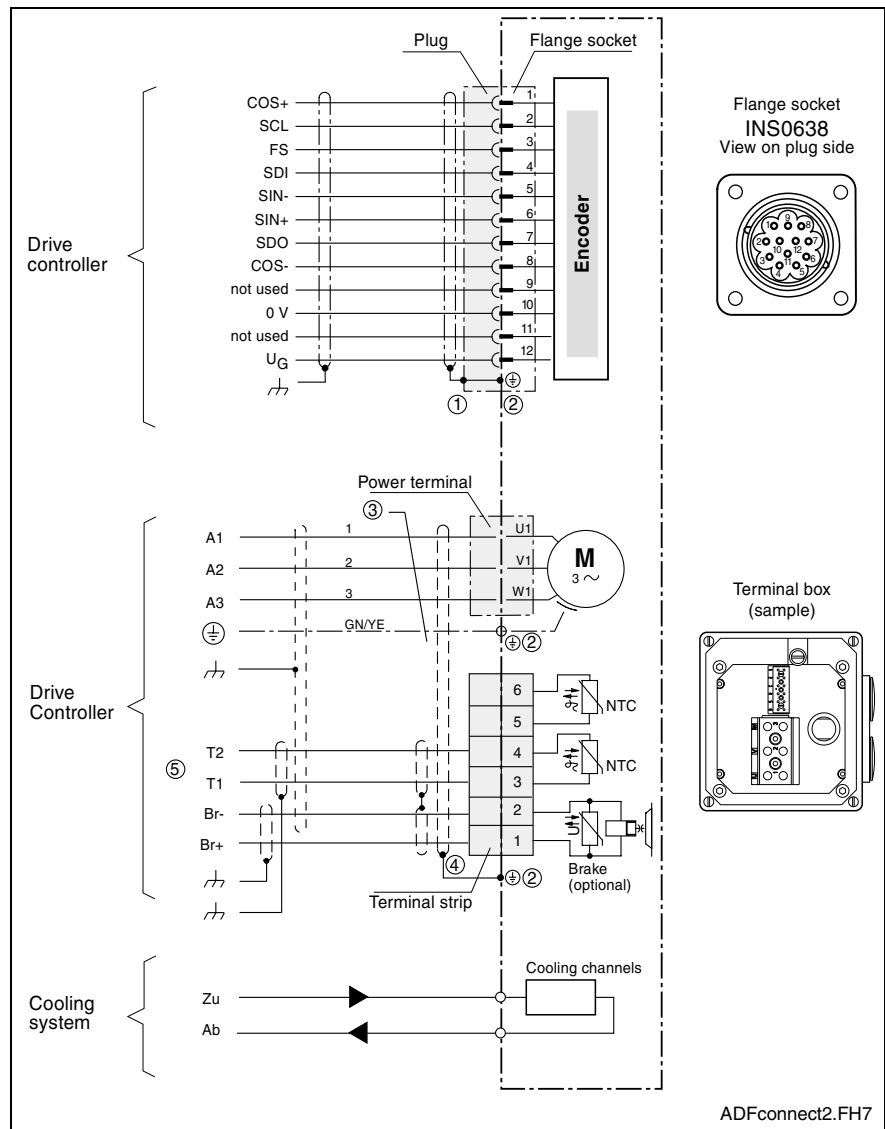

Fig. 10-3: ADF Power Plug Connection for ADF104/134/164

1. Put the plug into the flange socket, observing the correct coding.
2. Tighten the coupling ring manually until it locks into place (audible).
3. When the bayonet joint is locked, the red marking points at the flange box and the plugs must be opposite each other.

10.4 ADF with Terminal Box



- (1) Shielded connection via cable strain relief in the plug.
- (2): Electrically conductive connection to the motor housing
- (3): Minimum cross-section of power cable and plug; refer to motor data sheet and Fig. 10-1 "Power connections".
- (4): Shielded connection via cable strain relief in the PG threaded joint.
- (5): Only one NTC sensor is connected to drive controller. The spare sensor should only be connected when required.

Fig. 10-4: ADF with Terminal Box, Outline

Terminal Box

ADF motors with terminal boxes for drive combinations with a high DC-bus voltage (e.g. DIAX04 and ECODRIVE) are equipped with **terminal strips** for cable with wire ends or with **terminal boards** for cable with circular cable lugs.

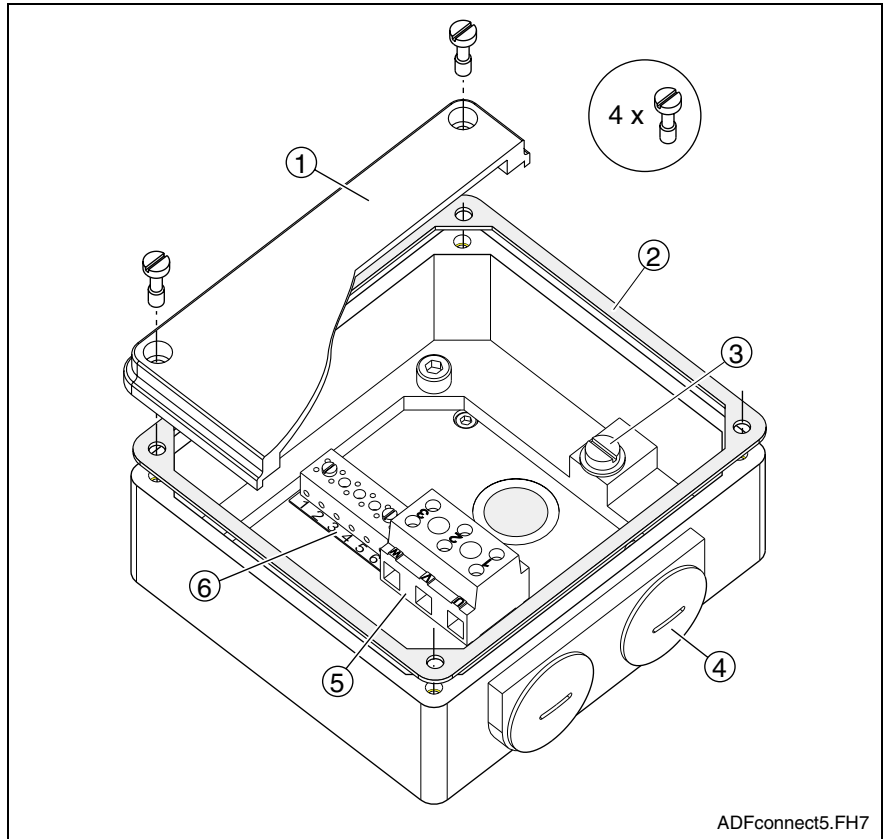

- | | | | |
|------|------------------------|------|-----------------|
| (1): | Cover | (2): | Sealing |
| (3): | Connection PE | (4): | Cable entry |
| (5): | Power connection U-V-W | (6): | Terminal strip. |

Fig. 10-5: ADF Terminal Box with Terminal Strips

The wiring assignment is shown in a diagram on the inside of the terminal box cover.

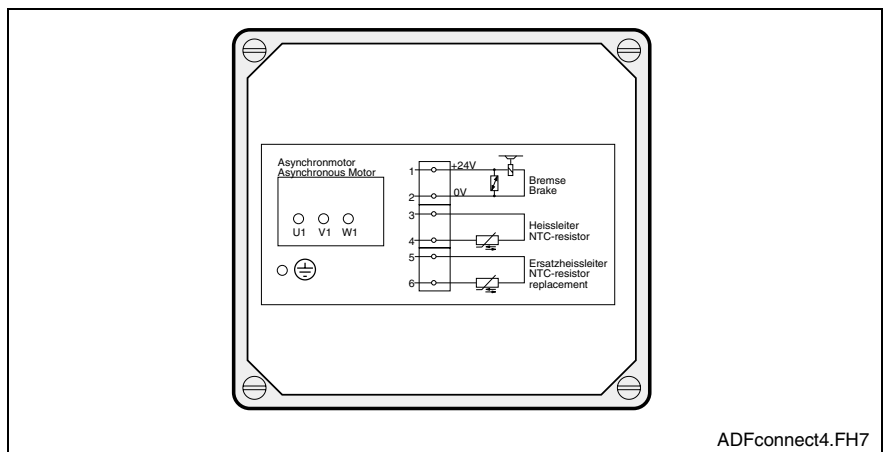

Fig. 10-6: ADF Terminal Box Connection

Note:

- The brake connections are only assigned when the motor has also been manufactured with the brake option.
 - Only one pair of contacts from the hot-connections 3-4 and 5-6 is connected to the motor cable. Polarity within a wire-pair is irrelevant.
 - The factory-installed gasket inside the cover must not be removed or damaged.
 - Observe the size of the PG threaded joint and the connection thread for the cable entry in the terminal box.
 - The motor's internal winding connections in the terminal box must not be disconnected.
-

10.5 Encoder Connection

The encoder connection at ADF motors is designed as a 12 pin flange socket at the encoder housing. The connection cable for connecting the motor encoder and the control unit must be equipped with a compatible plug at the motor side.

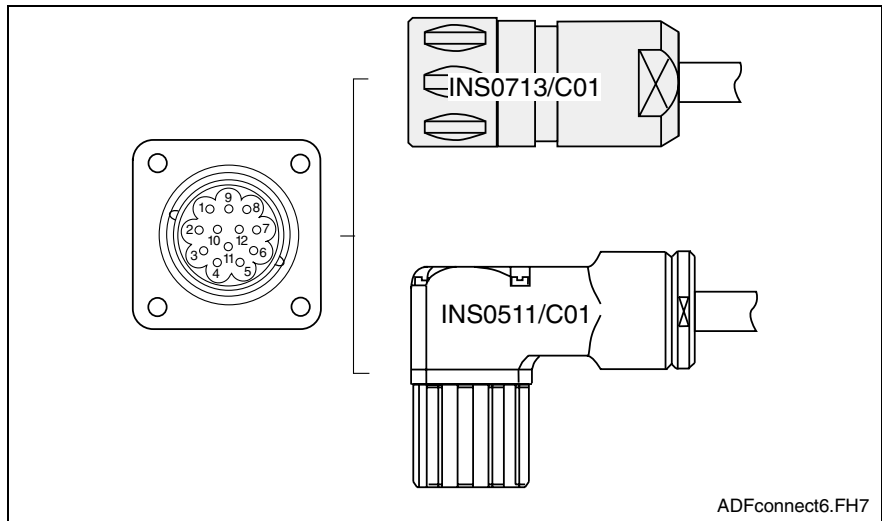

Fig. 10-7: ADF Encoder Flange Box

Note:

- Select the assembled cable with a straight plug or angular connector in accordance to the requirements of the system.
- Please observe in this regard section 8.1 of the documentation "Connection Cable for DIAX04, ECODRIVE03...", Mat.No. 00280894.

The motor's flange socket and the plug at the cable are plugged into each other and screwed on manually. They have therefore been designed as a mirror image of each other, i.e. with a different "polarity".

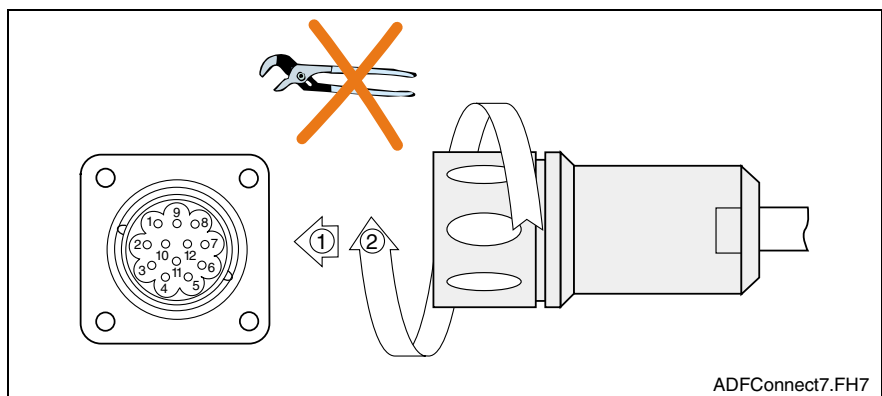

Fig. 10-8: ADF Example of an Encoder Plug Connection

1. Plug the plug into the flange box, observing the correct coding.
2. Tighten the coupling ring manually.

10.6 Brake

The motor holding brake is controlled either directly by the control unit or by an external control.

Note:

- The control voltage is +24 V_{DC}.
 - For a connection plan, refer to the connection diagram at the beginning of this chapter.
 - Observe the functional difference between electrically locking devices and electrically un-locking brakes (refer to chapter "Application Instructions").
-

10.7 Temperature Sensor

ADF motors are equipped with NTC temperature sensors that are firmly installed in the motor winding. There are two of each of the sensors.

Note:

- The signal lines of the NTC sensors are fed via the motor power cable to the controller. Polarity within the wire-pair is irrelevant.
 - Only one sensor is connected and monitored.
 - For a connection plan, refer to the connection diagram at the beginning of this chapter.
-

10.8 Motor Cooling

Following connections can be selected for individual motor models:

Motor	Connection via...		Note
	Thread	Quick Coupling [Ø d _i tube]	
ADF104	G1/8"	not available	1/8" = 1/8 inch
ADF134	G1/4"	9.6 mm	Selection of the connection acc. to type code
ADF164	G1/2"	12.7 mm	
ADF184	G1/2"	12.7 mm	

Fig. 10-9: ADF Survey of Cooling Connections

To supply the ADF motors with coolant, you require additional standard installation material such as tubes and fixing clips. These standard components are not included in the ADF delivery.

Select the supply tube with the correct inside diameter d_i.

The assignment of the inlet (IN) and the outlet (OUT) in the following diagrams has been made for reasons of standardisation and does not have any effect on the power specifications of the motor. Existing installations with other arrangements can be maintained.

Operating Pressure

The max. coolant pressure of **3 bar** is valid for all ADF motors. This pressure is related to the effective existing pressure directly present at the coolant connection of the motor.

Please observe that additional thread connections or branches in the cooling circuit may negatively influence the flow and the supply pressure of the coolant.

Coolant Connection ADF104

The machine's coolant system is connected the the G1/8" joint at the motor. The connection threads are covered at the factory by protective plugs.

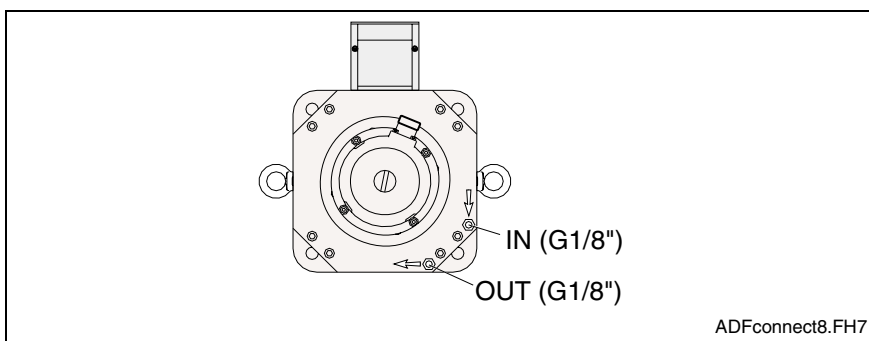
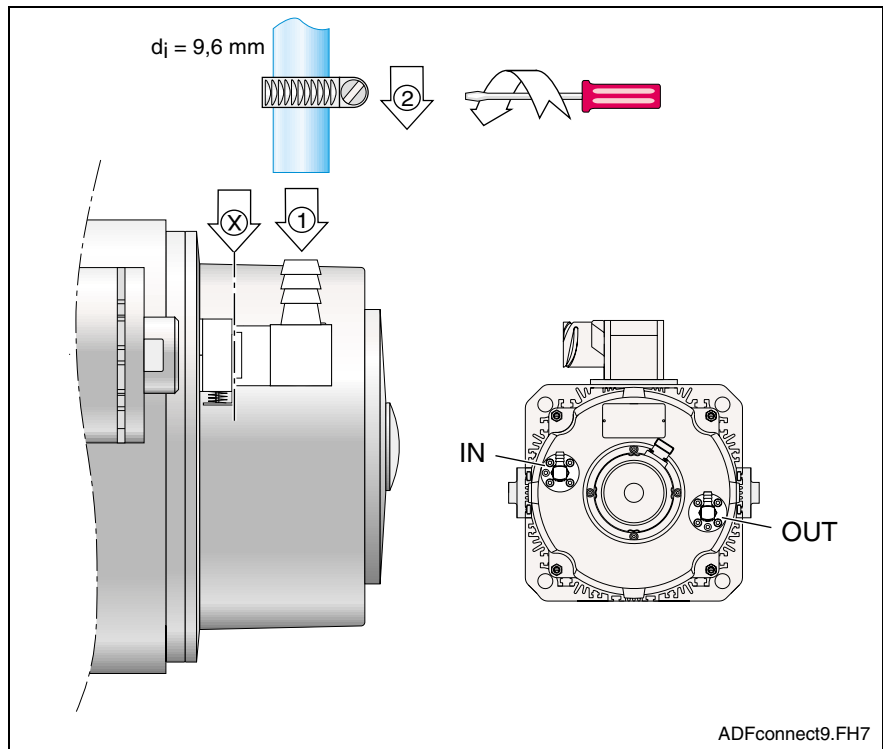

Fig. 10-10: ADF104 Cooling Connection

Cooling Connection ADF134



(X): Separation point

Fig. 10-11: ADF134 Cooling Connection (Example)

Procedure:

- ⇒ Push the tube onto the motor connection (1). Avoid bending or damaging the fittings at the motor .
- ⇒ Screw the end of the tube with the fixing clips (2) over the connection piece.
- ⇒ When servicing, the factory-installed fittings can be separated at point (X). Press the bolt and pull out the bracket in the axial direction. The tube must not be disconnected.



If you are using a different connection technique at the tube end then you may have to apply other assembly steps. Assembly instructions are available from the manufacturer of the equipment.

Cooling Connection ADF164/184

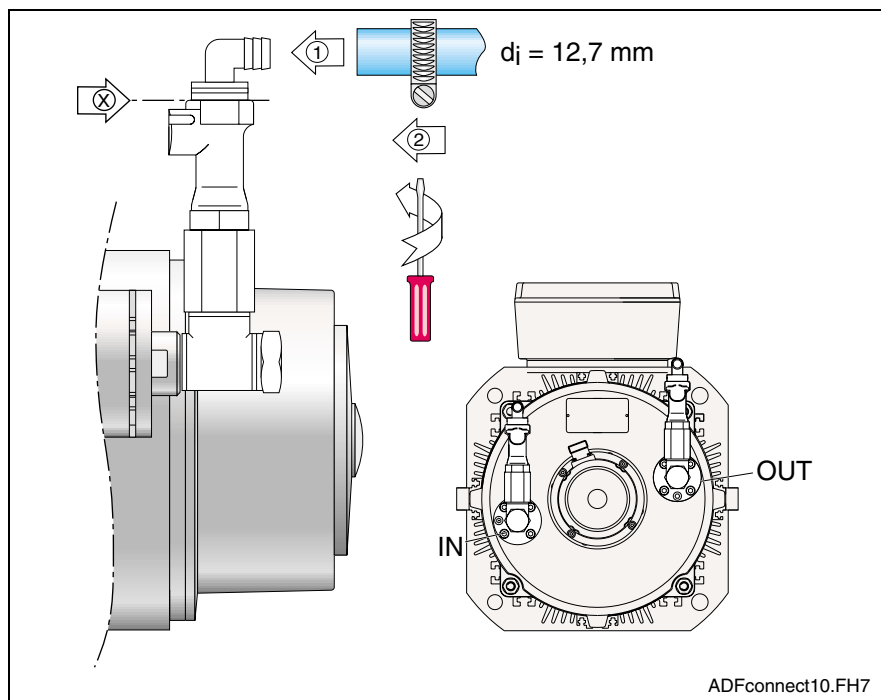

(X): Separation point

Fig. 10-12: ADF164/184 Cooling Connection (Example)

Procedure:

1. Push the tube onto the motor connection (1). Avoid bending or damaging the fittings at the motor end.
2. Screw the end of the tube with the fixing clips (2) over the connection piece.
3. When servicing, the factory-installed fittings can be separated at point (X). Press the locking button and pull out the bracket in the radial direction. The tube must not be disconnected.



If you are using a different connection technique at the tube end then you may have to apply other assembly steps. Assembly instructions are available from the manufacturer of the equipment.

11 Application Guidelines

11.1 Operating Conditions

Installation altitude and ambient temperature

The power specifications indicated for the drive system are valid for

- Ambient temperatures from 0° to +40° C
- Installation altitude from 0 m to 1000 m over sea level.

If you want to use drive systems outside of these ranges then the drive system data and power specifications must be reduced according to following diagrams. When both altitude and temperature are exceeded, the utilization factors must be multiplied.

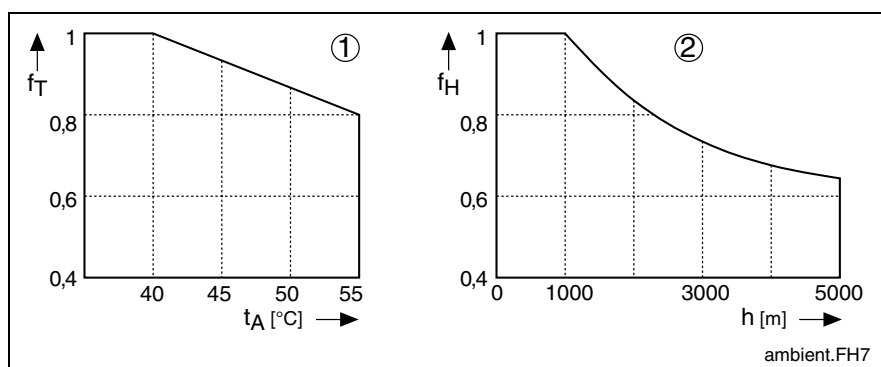

- (1): Utilization capacity dependent on the ambient temperature
 (2): Utilization capacity dependent on the installation altitude
 f_T : Temperature utilization factor
 t_A : Ambient temperature in Celsius
 f_H : Height utilization factor
 h : Installation altitude in meters

Fig. 11-1: Utilization Capacity

Note: The details for the utilization capacity depending on the installation altitude and the ambient temperature at a defined liquid cooling do not refer just to the motor, but to the entire drive system comprising the motor, drive controller and power supply.

Mechanical Environmental Conditions

According to IEC 721-3-3, edition 1987, ADF motors may be operated in stationary, weather-protected environments under following conditions:

- in relation to the longitudinal axis of the motor acc. to Class 3M1
- in relation to the lateral axis of the motor acc. to Class 3M6

For transport, storage and operation of ADF motors, the following maximum values therefore apply:

Sinusoidal Vibrations

Parameter	Unit	Maximum value in longitudinal axis	Maximum value in lateral axis
Amplitude of deflection at frequencies 2...9 Hz	mm	0.3	7.0
Amplitude of deflection at frequencies 9..200 Hz	m/s ²	1	20

Fig. 11-2: Maximum Values for Sinusoidal Vibrations

Shocks

Parameter	Unit	Maximum value in longitudinal axis	Maximum value in y axis
Total range of shock-response spectrum (acc. to IEC 721-1:1990, Tab. 1, section 6)		Type L	Type II
Max. acceleration	m/s ²	40	250
Duration	ms	22	6

Fig. 11-3: Maximum Values for Shocks

⇒ Make sure that the maximum values from Fig. 11-2 and Fig. 11-3 are not exceeded for storage, transport and operation.



Design and efficacy of shock-absorbing or shock-insulating attachments vary from case to case and must be tested by measurement. It is not within the scope of responsibility of the motor manufacturer. Changes in the construction of the motor result in a loss of guarantee.

11.2 Class of protection

The class of protection is determined by the shortform IP (International Protection) and two code numbers for the level of protection.

The **first code number** describes the level of protection against contact and infiltration of foreign bodies. The **second code number** describes the level of protection against water.

The class of protection according to IEC 60529 are valid for ADF motors. In all assembly positions, you must assure that the motors are not subjected to environmental conditions outside of the class of protection respectively in force according to IEC 60529.

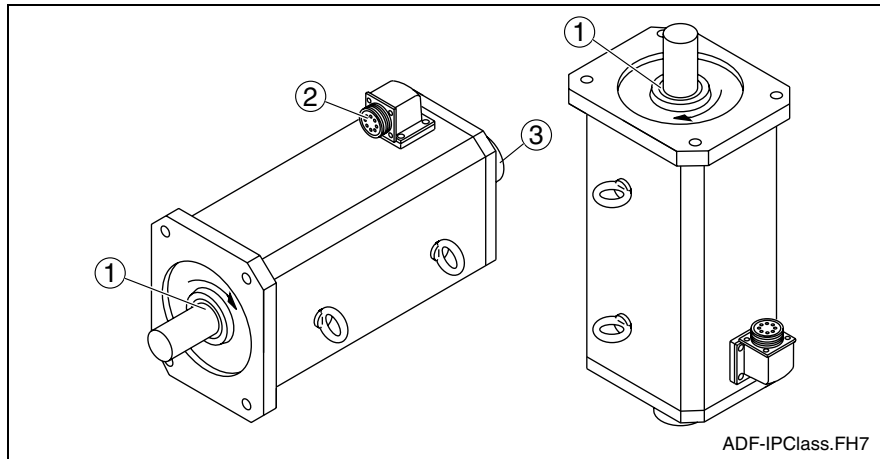

Fig. 11-4: ADF Class of Protection Ranges (sample picture)

Range of the Motor	System	Note
(1) Drive shaft without seal ring	IP54	
(1) Drive shaft without seal ring, vertical assembly acc. to M V3	IP40	
(1) Drive shaft with seal ring	IP65	optional
(2) Power connections	IP65	Terminal box or flange box
(3) Connection of motor encoder	IP65	Flange box
(3) Shaft end at B-side	IP65	in condition at delivery

Fig. 11-5: Motor Class of Protection

Note:

- Products and ranges with a low class of protection are not suitable for cleaning procedures with high pressures, steam or water jets.
- Even ranges with class of protection IP65 only provide a limited protection against invading liquids. The possible results are damage to the winding insulation and irreparable damage to the motor.
- Always observe the definition of the class of protections according to IEC 60529.

11.3 Installation in the Machine

Mounting positions

ADF motors can be delivered in types B05 and B35. The permissible mounting positions acc. to EN 60034-7 are listed in the following table.

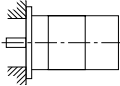
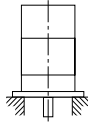
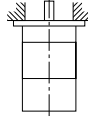
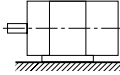
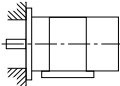
Motor Type	Permissible Mounting Positions		
	Designation	Sketch	Erection
B05	IM B5		Flange assembly on the drive side of the flange
	IM V1		Flange assembly on the drive side of the flange Drive side downwards
	IM V3		Flange assembly on the drive side of the flange Drive side upwards
B35	IM B3		Base mounting, feet down
	IM B5		Flange assembly on the drive side of the flange 1)

1) ADFs of type B35 can also be installed according to IM B5.

Fig. 11-6: ADF Mounting

Note:

- Installation according to IM B35 (base mounting with additional flange assembly) is not permitted!
- When installed vertically the grease life is reduced by approx. 30 %.

Base Assembly

In contrast to flange assembly, the radial forces in a base assembly may only be effective vertical to the assembly area. Transmission of forces with other effective directions of force is not permitted.

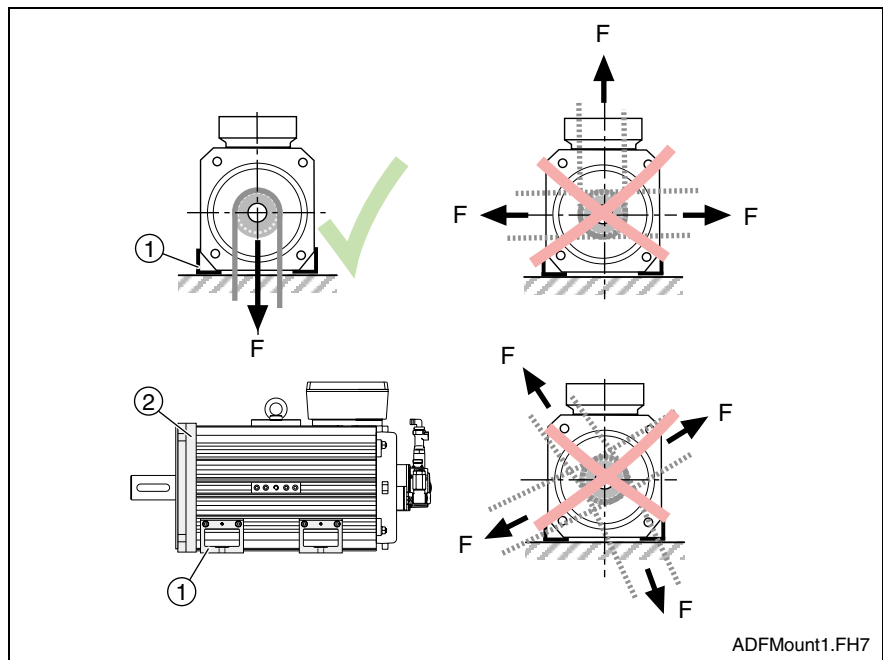

- (1): Mounting feet (base) for motor type B35
 (2): Flange for flange assembly with motor type B05

Fig. 11-7: ADF Base Assembly

Notes:

- Forces working on the feet of the motor that are transmitted by a gearbox are not permitted. Forces that are applied via the gearbox shaft must be supported at the gearbox.
- In an incorrect mounting position, forces arise that could result in short-term damage to the motor.
- Check the alternative "flange assembly".

Vertical Assembly

During vertical assembly, dirt and liquids can more easily penetrate into the insides of the motor and cause faults or breakdowns.

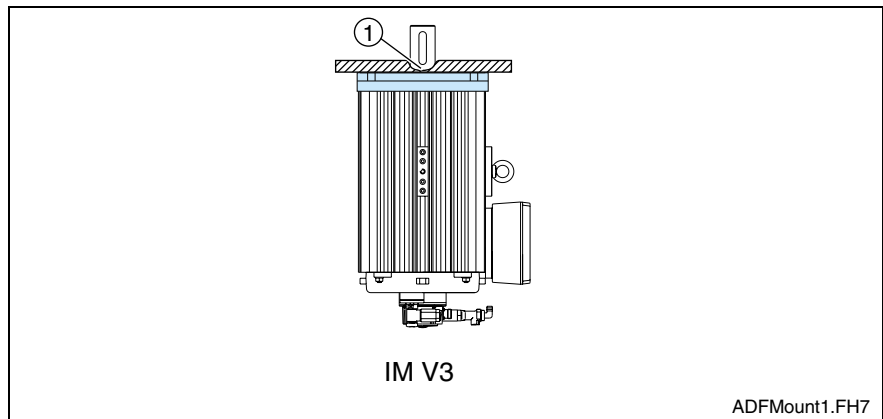

- (1): Shaft IP 40
Shaft bushing with radial shaft seal ring IP 65 (optional)

Fig. 11-8: ADF Vertical Assembly

Notes:

- **A-side:** Motors with shaft seal rings have the class of protection IP65 on the flange side. Tightness is only assured for splashes of liquid. The liquid levels arising at the drive side require a higher class of protection.
- **Class of protection:** The class of protection incorporated into ADF motors at the factory must not be reduced by modifications or the addition of accessories.

⇒ You should already consider the type of assembly and the class of protection of the motors when planning the system.

11.4 Brakes



DANGER

Dangerous movements! Danger to persons due to falling or lowering of axes!

- ⇒ The motor holding brake installed inside the motor is not suitable for personal safety!
- ⇒ You should assure the safety of persons by implementing special, fault-safe measures:
- ⇒ Block-off the danger area using protective equipment, e.g. protective fences.
- ⇒ After switching off the motor additionally secure vertical axes against falling or lowering by:
 - mechanical locking of vertical axes,
 - use of external brake/catching/locking equipment or
 - use of sufficient weight compensation of the axes

Brakes either lock electrically or release electrically. Due to the functional differences, different brakes should be used for the main spindle and for the servo axes. Observe the safety requirements when planning the system.

Functional Diagram

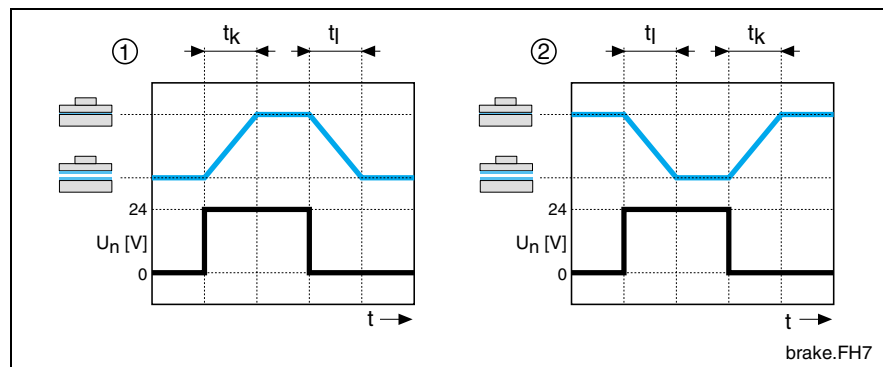

(1): Brakes lock electrically
 t_k : Lock delay

(2): Brakes release electrically
 t_l : Unlock delay

Fig. 11-9: ADF Diagram of Holding Brakes

Main Spindle Applications

The **electrically locking** holding brake is used for location of the main spindle at standstill and when "controller enable" is switched off, e.g. when changing a tool or when the position control loop is closed.

- ⇒ Only lock the brake when the motor has stopped and after the drive has reported that the motor has come to a standstill.

The **electrically unlocking** holding brakes should not be used by main spindle applications as the unintentional locking of the holding brake at high speeds results in the brake being destroyed (e.g. during a power loss or wire breakage).

Servo Applications

The **electrically unlocking** holding brake is used for stopping at standstill and when the "controller enable" is switched off. The **electrically unlocking** holding brake locks automatically during a power failure.

- ⇒ Do not use the holding brake as a service brake for rotating axes.
- ⇒ In case of hanging axes, only switch off the "controller enable" when the mechanics are at standstill and have already been locked by the holding brake.

If the brake is activated repeatedly when the drive is rotating or the permissible brake energy is exceeded, then this can result in premature wear.

The **electrically locking** holding brake is inappropriate for servo applications as the axis is not locked when there is no electrical power.

Load

Brakes may only be loaded to their respective maximum amount of permitted brake energy (refer to data sheet).

In case of electrically releasing brakes, the maximum permissible speed is therefore determined by the maximum brake energy W_{\max} of the holding brake. This is calculated as follows:

$$n_{\max} = \sqrt{\frac{2 \cdot W_{\max}}{J_M + J_B + J_L}} \cdot \frac{30}{3.14}$$

J_M : Moment of inertia of the rotor

J_B : Moment of inertia of the brakes

J_L : Moment of inertia of the load, reduced (attachments at the drive shaft)

Fig. 11-10: ADF Brake Energy

11.5 Motor Encoder

Options

"0": The motor is delivered from the factory without an encoder unit. The rear of the motor is closed with a lid.

"6": Incremental encoder with I²C-interface. Sine/cosine signals $1V_{pp}$ with 512 strokes per revolution and absolute period assignment within one turn of the shaft ("single turn").

"7": Incremental encoder with I²C-interface. Sine/cosine signals $1V_{pp}$ with 512 strokes per revolution and absolute period assignment within 4096 turns of the shaft ("multiturn"). The axis position remains stored during a power breakdown.

The incremental encoders are termed "digital servo feedback" (DSF).

Signals

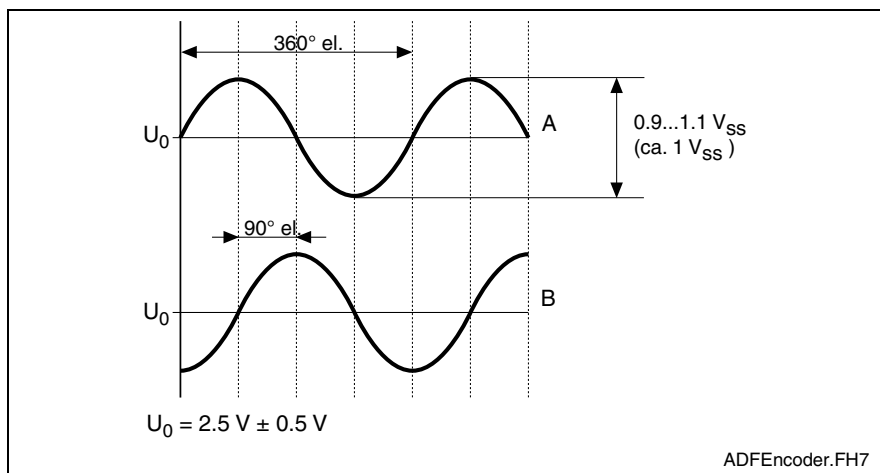

Fig. 11-11: ADF Encoder Signals



The accuracy of encoder systems is only a secondary factor for the precision of processing and positioning processes at a system. The determinative factors for the achievable precision are, among other things, the functionality of the system and the quality of its mechanical construction.

Compatibility

ADF motors with the encoder option "6" or "7" are compatible to the DIAX03, DIAX04 and ECODRIVE product series. Drive controllers from these product series can read-out the data stored in the encoder and process this data for drive parameterisation. Please observe the specifications in the documentation for the respective drive controller.

Connection

The encoder connection is always at the same side of the motor as the power connection. The position of the encoder connection can not be changed after the motor has been delivered. For details, refer to the chapter named "Connections".

11.6 Drive Shaft

Standard Shaft

The recommended standard shaft without keyway offers a gradually engaged, tight shaft-hub connection with an extremely even run. Use tensioning kits, ferrules or other coupling elements to connect motor shaft and machine elements to be driven.

Drive Shafts with Keyways

The key option according to DIN 6885, sheet 1, edition 08-1968, allows the positive transmission of the directionally constant torque with low demands made on the shaft-hub connection.

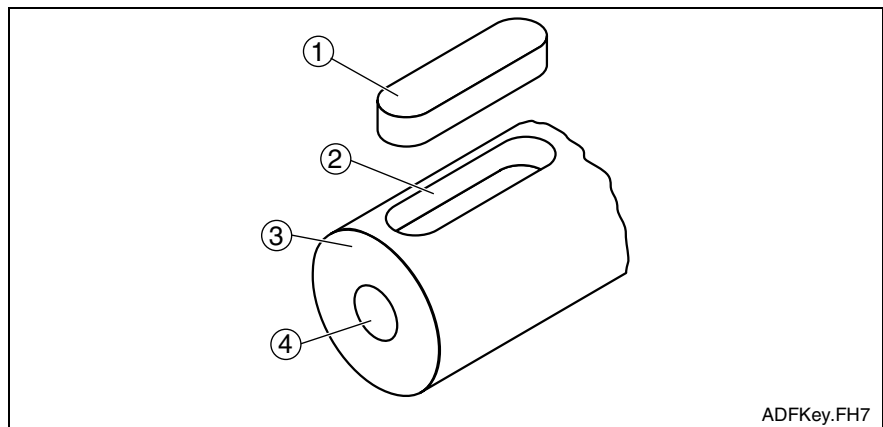

- | | | | |
|------|--------|------|--------------------|
| (1): | Key | (3): | Motor shaft |
| (2): | Keyway | (4): | Centering borehole |

Fig. 11-12: ADF Drive Shaft with Keyway

The machine elements to be driven must be additionally secured (axial) via a centering borehole on the front end.

⇒ Avoid strong reversing operation. Deformations around the keyway can result in a shaft break.

Balancing with a half key

The motor is balanced using a half key. The mass ratios are comparable to those of the standard shaft. If an entire key is inserted then there is an imbalance, that must be balanced at the machine elements to be driven.

The hub of a driven machine element (pinion, belt pulley, etc.) should correspond to the length of the key.

⇒ For shorter hubs, use graded keys.

Balancing with whole keys

The motor is balanced using the keys delivered. The machine element to be driven must therefore be balanced without keys. The length of the keyway in the hub depends on the length of the keys.

Note: Modifications to keys or keyways can only be carried out by the user himself and on his own responsibility. Rexroth Indramat does not accept any liability for modified keys or keyways on motor shafts.

Drive Shaft with Shaft Seal Ring

Using the optional radial shaft seal ring according to DIN 3760 - Model A, ADF motors are suitable for e.g. assembly of gearboxes with oil bath or recirculating oil lubrication systems.

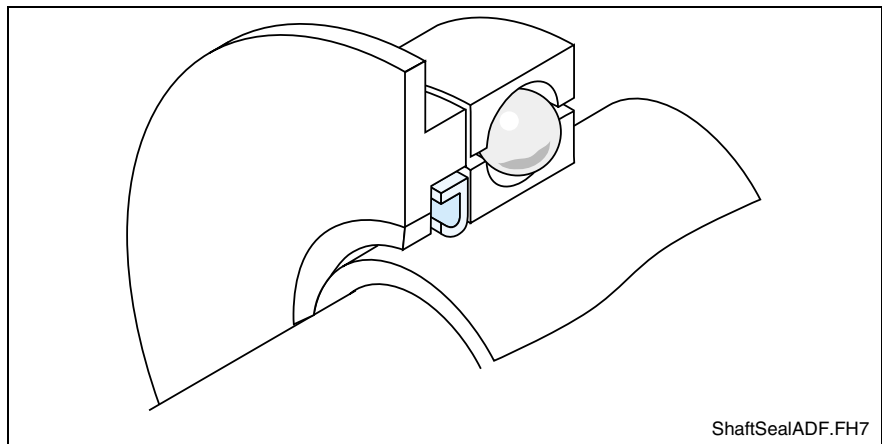

Fig. 11-13: ADF Radial Shaft Seal Ring

Wear Radial shaft seal rings are grinding seals. They are therefore always subject to wear and also generate frictional heat.

Signs of wear to the grinding seals can only be reduced by sufficient greasing and keeping the sealing points clean. The lubricant works here both as a cooling agent and in supporting the removal of frictional heat from the sealing point.

⇒ Avoid dry runs and contamination of the sealing area with dirt. Always make sure that the equipment is clean and sufficiently lubricated.

Durability The materials used for radial shaft seal rings have a high level of durability against oils and chemicals. However, the qualification & durability tests for the respective operating conditions are the responsibility of the machine manufacturer.

Materials Used At the time of printing this document, the following material has been assigned:

Motor	Sealing Material	Short Form
ADF104/134/164	Polytetrafluorethylene	PTFE
ADF184	Flourine rubber	FPM

Fig. 11-14: ADF Shaft Seal Ring



The complex interaction between seal ring, shaft and the liquid to be sealed, as well as the respective operating conditions (frictional heat, soiling, etc.) make any calculation of the lifetime of the shaft seal ring impossible. In unfavourable conditions, experience has shown that the probability of a breakdown increases after 2000 operating hours.

Vertical Assembly Positions IM V3/IM V6

Motors with shaft seal rings are equipped with the class of protection IP65 on the drive side. Tightness is thereby only assured for splashes of liquid. Liquids arising at the A side require a higher class of protection. When assembling the motor in a vertical position, please observe the additional instructions in the section entitled "Vertical Assembly" in this chapter.

11.7 Bearing and Shaft Load

During operation, radial and axial forces are applied to the motor shaft and thereby also to the bearing.

The machine construction and the motor type must be carefully matched to each other so that the load limits of the shaft and the bearing are not exceeded.

Options

Some ADF motors can be delivered with standard bearings or with reinforced bearings.

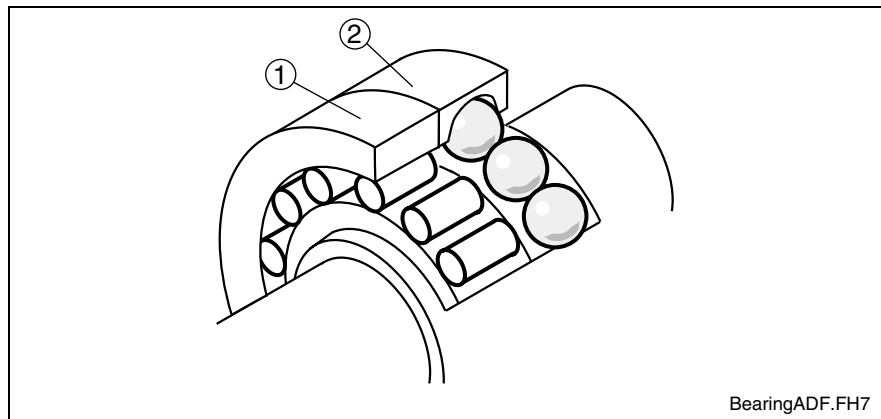

- (1): Cylinder roller bearing
 (2): Deep-groove ball bearing

Fig. 11-15: ADF Motor Bearing

- Standard bearing "N" = deep-groove ball bearing
- Reinforced bearing "V" = deep-groove ball bearing + cylinder roller bearing

Standard Bearing Standard bearing type for ADF motors are deep-groove ball bearings.

Advantages:

1. High level of availability and lifetime
2. Suitability for high speeds
3. Low-noise when running

Disadvantages:

Deep-groove ball bearings are only suitable for medium radial and axial loads.

Reinforced Bearing The reinforced bearing is equipped with an additional cylinder roller bearing on the drive side.

Advantages:

The reinforced bearing can accommodate larger radial forces.

Disadvantages:

1. The grease life of the reinforced bearing is reduced to half of the standard value.
2. For some motors, the maximum permissible speed is reduced.
3. Motors with reinforced bearing may only be operated with a permanent radial load (see Fig. 11-16: ADF Radial Load). The bearings could be damaged by running friction.

- ⇒ Select the "reinforced bearing" option only in exceptional cases.
- ⇒ Observe the respective details in the "Technical Data ADF...".

Motors with reinforced bearings must be operated with the following permanent radial load:

ADF	104	134	164	184	
Permanent radial load [kN]	not available	1	1.5	2	

Fig. 11-16: ADF Radial Load

Radial Load

The permissible radial load at the drive shaft is determined by the type of bearing, the model of shaft and the mean speed n_m .

1. The permissible load values are contained in the corresponding diagram in the chapter entitled "Technical Data..." of this manual. Do not exceed the permissible load values.
2. Observe the reduced limit values for shafts with keyways as outlined in the diagrams.
3. Calculate the "mean speed" as an average speed driven over the entire processing cycle.

Mean Speed

Running up time and braking time can be omitted in the calculation because the time in which the drive is driven at a constant speed is much larger than the acceleration and braking time. In the exact calculation of the mean speed using the following sample, the running up time and the braking time have also been considered.

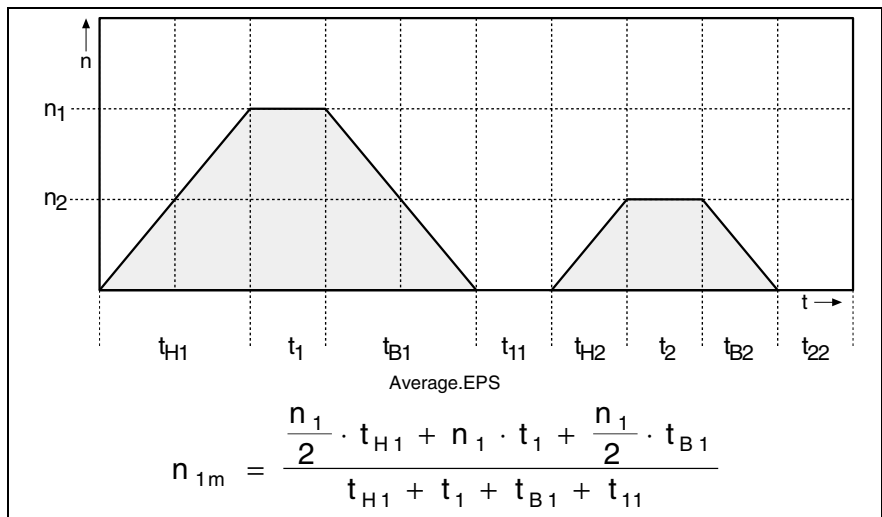

- | | | | |
|------------|-----------------------|------------|-----------------------|
| n_{1m} : | Mean speed, section 1 | n_{2m} : | Mean speed, section 2 |
| n_1 : | Processing speed | n_{2m} : | Processing speed |
| t_{H1} : | Running up time | t_{H2} : | Running up time |
| t_1 : | Processing time | t_2 : | Processing time |
| t_{B1} : | Braking time | t_{B2} : | Braking time |
| t_{11} : | standstill time | t_{22} : | standstill time |

Fig. 11-17: ADF Mean Speed

One complete processing cycle can consist of several sections with various speeds. In this case, the average is to be formed from all sections.

Axial Load

Only low axial shaft loads are permitted for ADF motors (refer also to "Technical Specifications ADF.."). ADF motors are therefore **not** suitable for machine elements that generate the axial loads of the ADF motor (e.g. sloped, toothed drive pinions).

ADF	104	134	164	184
Axial load [N]	30	50		

Fig. 11-18: ADF Axial Load

The permissible axial load is valid for all assembly positions.

⇒ Avoid forbidden axial loads or impacts to the motor shaft.

Lifetime

The lifetime of the bearing is an important criteria for the availability of the ADF motors. When considering the lifetime of the bearing, a difference is made between the "mechanical lifetime" of bearing components and material and the "grease life" of the bearing lubricant.

Mechanical Lifetime The mechanical lifetime of the bearing is 20000 hours. This applies to all ADF motors based on the following:

- The permissible loads from the respective chapter "Technical Specifications ADF.." are not exceeded at any time.
- The motor is operated under the permitted conditions of use and within the permissible ambient temperature range of 0° to +40° C.
- The "mean speed" run over the entire processing cycle conforms to the guidelines for the grease life from the respective chapter "Technical Specifications ADF..", whereby the following applies:

$$n_m < n_{m(t_f = 20000 \text{ h})}$$

n_m : Mean Speed

$n_{m(t_f)}$: Mean speed at which a grease life of 20000 h can be expected.

Fig. 11-19: ADF Mean Speed

Deviations to these loads may result in the following:

- Premature breakdown of the bearing due to increased wear or mechanical damage.
- Reduction in the grease life and thereby a premature breakdown of the bearing

⇒ Do not exceed the permissible load values.

Grease Life The deep-groove ball bearing and the cylinder roller bearing in ADF motors are greased for life. The grease life to be expected is shown in a diagram in the chapter entitled "Technical Data ADF.." and should be determined for every use.

In the diagram, various guidelines are contained for the "standard bearing" and the "reinforced bearing". The guidelines for the grease life for ADF motors is based on the following:

- The permissible loads from the respective chapter "Technical Data ADF.." are not exceeded at any time.
- The higher the "mean speed" that is driven over the entire processing cycle is, the smaller will be the available grease life.

When the available grease life has expired, the probability that the bearing and the motor break down, will increase. Particularly in cases where the motor has a reinforced bearing, this can lead to a much lower motor operating time.

If the availability of the motor is limited by a short grease life then the motor availability can be extended in some special cases by using the standard bearing instead of the reinforced bearing, whereby the grease life increases. However, the higher load of the standard bearing reduces the available mechanical lifetime to under 20000 operating hours.

This case requires that the lifetime of the bearing be recalculated by REXROTH INDRAMAT. Please contact one of our branches and provide us with details of usage and all relevant application data (load cycle, axial and radial loads, speeds).



Calculation and design of the bearing is based on the standard DIN ISO 281.

Selection Help

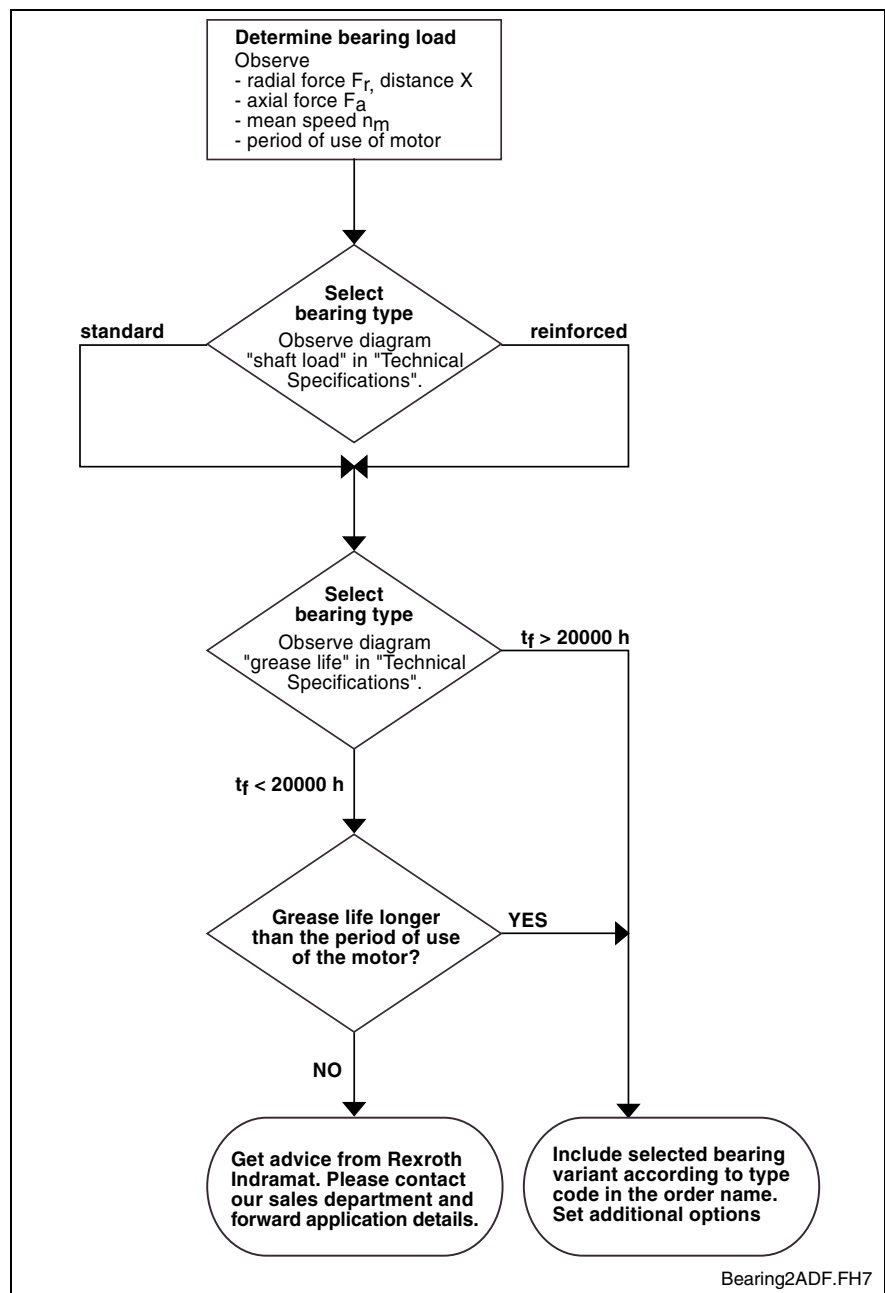

Fig. 11-20: ADF Selection of Bearing

11.8 Vibration Level

ADF motors are dynamically balanced according to DIN ISO 2373.

The vibration level R is the standard for all ADF motors. For particular demands on smooth mechanical running, levels S and S1 are available for some motors. Please observe the limitations in the individual type codes.

Vibration Level	Effective Vibration Speed V_{eff} in [mm/s]							
	ADF104-134				ADF164-184			
	Speed n [min^{-1}]				Speed n [min^{-1}]			
	600-1800	1800-3600	3600-6000	6000-8000	600-1800	1800-3600	3600-6000	6000-8000
R	0.71	1.12	1.8	2.8	1.12	1.8	2.8	4.5
S	0.45	0.71	1.12	1.8	0.71	1.12	1.8	2.8
S1	0.28	0.45	0.71	1.12	0.45	0.71	1.12	1.8

Fig. 11-21: ADF Effective Vibration Speed

The vibration behaviour of attached or driven machine elements can generate responses on the ADF motor that, in unfavourable cases, can result in premature wear or breakdown.

Due to the system-specific influences on the vibration behaviour of the entire system, the machine manufacturer must determine the exact facts.

In certain cases, it may be necessary to balance the elements to be driven in such a way that there are no resonances or responses.

⇒ You should already consider the vibration behaviour of the motor and the machine elements when planning the system.

11.9 Temperature Sensor

ADF motors are equipped with NTC temperature sensors that are firmly installed in the motor winding and that serve for the internal determination of the winding temperature. The sensors are connected and evaluated at the control unit.

- The NTC sensors are not safety devices and have not been designed to be incorporated into the safety system for the protection of persons or of the machine.
- The NTC sensors are neither suitable for determining the temperature at the motor housing nor for that of the rotor or the temperature at the bearings.
- Additional temperature monitoring requirements must be implemented by the machine manufacturer.

11.10 Motor Cooling

The power loss P_V of the motor is converted into heat and dissipated by the cooling system. ADF motors may therefore only be operated when the supply of coolant is assured. The cooling system must be designed by the machine manufacturer in such a way that all requirements on throughput, pressure, purity, temperature drops, etc. are observed in all operating conditions.



CAUTION

Adverse effects or breakdown of motor, machine or cooling system!

- ⇒ Always consider the motor specifications and the explanations on the design of cooling systems contained in the documentation "Liquid Cooling..., Dimensioning, Selection", Mat.No. 00265836.
- ⇒ When constructing and operating cooling systems, always observe the regulations of the manufacturer.
- ⇒ Do not use any cooling lubricant or cutting materials from machine processes.

Coolant

All details and technical specifications refer to water as the coolant. This data is no longer valid, and must be redetermined, if other coolants are used.

Cooling with running water from the public water supply is not recommended. Calcareous water can cause deposits or corrosion and damage both the motor and the cooling system.

For corrosion protection and for chemical stabilisation, an additive must be mixed in with the cooling water that is suitable for machine installations with materials as shown in Fig. 11-23.

The use of aggressive coolants, additives or cooling lubricants can result in irreparable damage to the motors.

- ⇒ Use systems with closed circuits and fine filters = 100 µm.
- ⇒ When selecting the coolant, observe the environmental regulations and the regulations on disposal.

Watery Solution

Watery solutions assure reliable corrosion protection without any significant changes to the physical characteristics of the water. The recommended additives do not contain any materials that are a danger to the water.

Emulsion with Corrosion Protection

Corrosion protection oils for cooling water circuits contain emulgators that are responsible for the fine distribution of the oil in water. The oily components in the emulsion protect the metal surfaces of the coolant channel from corrosion and cavitation. An oil content of 0.5 to 2 Vol.-% has proven reliable.

If, in addition to corrosion protection, the corrosion oil is also to lubricate the coolant pump then an oil content of approx. 5 Vol.-% is required.

- ⇒ Observe the regulations of the manufacturer of the equipment!

Coolant Additives Examples of coolant additives:

Designation	Manufacturer
1%...3% solutions	
Aquaplus 22	Petrofer, Hildesheim
Varidos 1+1	Schilling Chemie, Freiburg
33% solutions	
Glycoshell	Deutsche Shell Chemie GmbH, Eschborn
Tyfocor L	Tyforop Chemie GmbH, Hamburg
OZO frost protection	Deutsche Total GmbH, Düsseldorf
Aral Kühler-Frostschutz A	ARAL AG, Bochum
BP antifrost X 2270 A	Deutsche BP AG, Hamburg
Emulsifying mineral oil concentrate	
Shell Donax CC (WGK: 3)	Shell, Hamburg

Fig. 11-22: Coolant Additives

Note: Rexroth Indramat can not make any general statements or examinations regarding the suitability of system-specific coolants, additives or conditions of use.

The performance test for the coolants used and the design of the liquid cooling system are normally within the scope of responsibility of the machine manufacturer.

Materials Used

When used in ADF motors, the coolant comes into contact with the following materials:

ADF	Motor, Housing	Threaded Joints	Quick Coupling
104	AlMgSi0.5, GGG40, NBR, St37	---	---
134	CU, CuZn39Pb2	brass, chrome coated	brass, chrome coated
164	CU, CuZn39Pb2	brass, chrome coated	Polysulfon
184			

Fig. 11-23: ADF Material

Chemical or electrochemical interactions with subsequent corrosion or decomposition of motor parts.

Coolant Temperature

The permissible temperature range of the coolant is 15...40°C. This temperature range must be observed at all times.

- Thermal damage to components can occur at higher temperatures.
- Due to higher temperature gradients, lower temperatures can result in the destruction of the motor.

12 Handling and Transport

12.1 Condition on Delivery

ADF motors are packed in wooden boxes or in cartons on delivery (ADF104). Packing units on pallets are secured by tension bands.



CAUTION

Injuries due to uncontrolled movements of the tension bands when unpacking!

⇒ Keep a safe distance and cut the tension bands carefully.

Motor shafts and plug connections are provided with sleeves at the factory. Only remove the sleeves immediately before assembly.

Factory Checks

Additionally to all quality inspections during manufacturing and testing ADF motors are subjected to the following tests before delivery:

Electrical Test

- High-voltage test acc. to EN 60034-1 (corresponds to VDE 0530-1).
- Insulation resistance acc. to EN 60204-1/1.92, Section 20.3.
- Ground wire connection acc. to EN 60204-1/1.92, Section 20.3.

Mechanical Test

- True running and geometric tolerances of shaft end and mounting flange acc. to DIN 42955.
- Vibration testing acc. to DIN 2373.

Checks made by the Customer

As all ADF motors are subjected to a standardized test procedure, high-voltage testing is not required by the customer. Motors and components can be damaged by repeated high-voltage tests.



CAREFUL

Destruction of motor components caused by improper high-voltage tests! Loss of guarantee!

⇒ Avoid repeated high-voltage tests.

⇒ Observe the regulations contained in EN 60034-1 (corresponds to VDE 0530-1)

12.2 Identification

The total scope of a delivery is contained in the delivery note or the consignment note. The content of a delivery can, however, be distributed over several packages. Every individual package can be identified by the delivery sticker attached on the outside of the package.

Every device has its own type plate containing the name of the device and technical specifications.

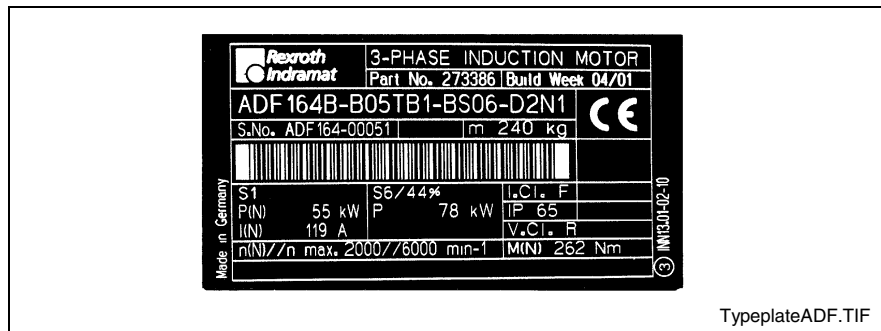

Fig. 12-1: ADF Type Plate (Sample)

⇒ After receiving the products, make a comparison of the type ordered and the type delivered. Immediately file a complaint if these do not agree.

12.3 Transport and Storage



CAREFUL

Damage or injury with loss of guarantee caused by improper handling! Heavy equipment!

- ⇒ Protect the products from damp and corrosion.
- ⇒ Avoid mechanical loads, throwing, tilting or falling of the product.
- ⇒ Always use suitable lifting equipment at the transport rings of the motor.
- ⇒ Never lift the motor by its plugs, cable or connection fittings.
- ⇒ Use suitable protective equipment and protective clothing during transport.
- ⇒ Store the motors dry, free from vibration and protected against corrosion in a flat position. The permissible temperature range is -20 °C to $+80\text{ °C}$.

Observe the instructions regarding storage and transport on the packaging.

On delivery, ADF motors are provided with sleeves and covers. The sleeves must remain on the motor during transport and storage.

- ⇒ Only remove the sleeves immediately before assembly.
- ⇒ Also use the sleeves when returning equipment to prevent further damage.

13 Installation

13.1 Safety



WARNING

Injuries due to live parts! Lifting of heavy loads!

- ⇒ Install the motors cold and when not connected to the electrical power supply.
- ⇒ Use suitable lifting equipment, protective equipment and protective clothing during transport.
- ⇒ Do not lift or move the motor by or at the fan unit.
- ⇒ Observe the safety instructions in the previous chapters.

Carry out all work steps with particular care. This minimizes the risk of accidents and damage.



Some ADF motors are equipped with additional threaded boreholes along their sides for attaching transportation rings (for details refer to the dimensional drawing). You can facilitate handling and transport using additional transportation rings.

13.2 Mechanical Installation

Fixing Boreholes

ADF motors are produced either for flange mounting (model B05) or for base (foot) mounting (model B35). Details regarding the fixing boreholes are contained in the respective dimensional drawing. The following assignment applies for the fixing of the motor:

ADF	B05 (flange mounting)			B35 (base mounting)		
	borehole	screw 1)		borehole	screw 1)	
	Ø [mm]	Type	M _{GA} [Nm]	Ø [mm]	Type	M _{GA} [Nm]
104	14	M12	87	11	M10	51
134	18	M16	215	12	M10	51
164	18	M16	215	14	M12	87
184	18	M16	215	14.5	M12	87

1) The type and the tightening torque is recommended for screws of the fixing class 8.8. M_{GA} = tightening torque in Newton-Meter.

Fig. 13-1: ADF Fixing Boreholes

Note: The screw connections must be able to handle both the weight of the motor as well as any forces that occur when in operation.

Preparations

- ⇒ Log all of the measures carried out in the commissioning protocol.
- ⇒ Assemble required accessories such as the "labyrinth seal" (SUP-M02-ADF...) or the cooling tube joints before mounting the motor. The assembly instructions for the labyrinth seal are contained in the accessories set.

Prepare the mounting of the motor as follows:

1. Check whether any components have any visible damages. Damaged parts must not be assembled.
2. Make sure that dimensions and tolerances at the machine are suitable for installing the motor (for details refer to the dimensional drawing).
3. Make sure that the assembly is carried out in clean and dry environment.
4. Have tools and required accessories ready, as well as measuring and test equipment.
5. Check all components, assembly surfaces and threads for cleanliness.
6. Make sure that the seat for the motor flange at the machine is free of burrs.
7. Remove the sleeve from the motor shaft. Store the sleeve for later use.

Mounting

- ⇒ Mount the motor and fix all screws with the dedicated tightening torque.

Observe the following:

- ⇒ Avoid blocking or sticking of the centering collar at the motor end.
- ⇒ Avoid damages to the attachment fitting at the machine.
- ⇒ Observe the permissible tightening torque for screw connections.
- ⇒ Check the tightness and accuracy of the connection before carrying out any other steps.
- ⇒ Check the connection and setting of the cooling system
- ⇒ When required, deair the cooling circuit according to the instructions of the manufacturer.

After correct mechanical assembly, proceed with the electrical connection.

13.3 Electrical Connection

Preferably use the ready-made cables from REXROTH INDRAMAT. These cables have many advantages such as UL/CSA certification, extreme loadability and resistance as well as EMC conformity.

⇒ Carry out the electrical connection of the ADF motor as specified in the chapter entitled "Connections".

Note:

- When assembling cables yourself, make sure that these are designed and installed in conformity to the EMC requirements.
 - The connection plans of the product documentation are used in writing up the machine circuit diagrams. The machine circuit diagrams of the machine manufacturer are solely determinative for the connection of the drive components in the machine.
 - ADF104, 134, 164 and 184 are generally suitable for drive combinations of the DIAX04 and ECODRIVE product ranges with higher DC-bus voltage (up to 750V).
-

14 Operation of ADF Motors

14.1 Commissioning

The following commissioning instructions refer to the ADF motor as part of a drive system with drive controller and control system.

Preparations

1. Have the documentation of all products used at hand.
2. Log all of the measures carried out in the commissioning protocol.
3. Check the products for damages.
4. Check all mechanical and electrical connections.
5. Activate safety equipment and monitoring systems within the system.



CAREFUL

Equipment damage due to errors in the control of motors and moved elements! Unclear operating conditions and product data!

- ⇒ Do not put into operation when connections, operating conditions or product data are unclear or faulty!
- ⇒ Do not put into operation when safety equipment and monitoring equipment of the system are damaged or not in operation.
- ⇒ Damaged products must not be put into operation.
- ⇒ Request missing information or support for commissioning from REXROTH INDRAMAT!

Actions

When all requirements have been fulfilled, carry out the following steps:

1. Activate the external cooling system for the supply of the ADF motor and check its condition of order. Observe the instructions of the cooling system manufacturer.
2. Put the control units and power supplies into operation in accordance to the respective instructions. Observe the respective product documentation.
3. Before enabling the command set-points, check whether the programmed ratio between the maximum speed of the motor and the controller set-point corresponds to the specifications of the machine.
4. At low speed, check whether the direction of rotation of the motor and the command set-point polarity correspond to the specifications for the machine.
5. At low speed, check whether the positioning commands of the control system are correctly executed.
6. Log all of the measures carried out in the commissioning protocol.

When all steps have been carried out correctly, the commissioning of the motor has been completed.



The commissioning of drive controllers and control systems may make other steps necessary. The check of functions and performance of systems is not a part of the motor commissioning but is carried out within the general start-up of the machine. Observe the details and regulations of the machine manufacturer.

14.2 Shutdown

Carry out the following steps during faults, maintenance work or a shutdown of the motor:

1. Observe the instructions in the machine documentation.
2. Use machine control commands to bring the drive to a controlled standstill.
3. Switch off the power and control voltage of the control unit.
4. Switch off the motor protection switch for the motor fan.
5. Switch off the main switch of the machine.
6. Secure the machine against unforeseen movements and against operation by unauthorized persons.
7. Wait for the discharge time of the electrical systems and then disconnect all electrical connections.
8. Secure the motor and supply lines against falling or moving before you disconnected the mechanical connections.
9. Log all of the measures carried out in the commissioning protocol or machine maintenance plan.

14.3 Disassembly



DANGER

Lethal injuries due to errors in the control of motors and work at moved elements!

- ⇒ Do not work at systems that are running or that are unsecured.
- ⇒ Before disassembly, secure the machine against unforeseen movements and against operation by unauthorized persons.
- ⇒ Secure the motor and supply lines against falling or moving before you disconnect the mechanical connections.

1. Observe the instructions in the machine documentation.
2. Observe the safety instructions and carry out all steps in accordance to the previous instructions "14.2 Shutdown".
3. Disassembly the motor from the machine and store it correctly.
4. Log all of the measures carried out in the commissioning protocol or machine maintenance plan.

14.4 Maintenance

Asynchronous motors ADF work within the predefined operating conditions and lifetime maintenance-free. Operation in unfavourable conditions can, however, result in limitations to the availability.

- ⇒ Increase the availability of the system by carrying out regular, preventive maintenance measures.
- ⇒ Observe the details provided by the machine manufacturer in the machine maintenance plan.
- ⇒ Log all maintenance measures in the machine maintenance plan.

Measures



DANGER

Danger of injury due to moving elements! Danger of injury due to hot surfaces!

- ⇒ Do not carry out any maintenance work at machines that are running.
- ⇒ This work may only be carried out by trained personnel.
- ⇒ During maintenance work, secure the system against re-starting and against unauthorized use.
- ⇒ Do not work at hot surfaces.
- ⇒ Secure open supply lines and connections against contamination with dirt.

REXROTH INDRAMAT recommends the following maintenance work based on the maintenance plan of the machine manufacturer:

Measure	Interval
Check function of the cooling system.	As specified in the machine maintenance plan, but at least every 1000 hours of operation.
Rinse, clean and deair cooling system. Renew filter system.	As specified in the machine maintenance plan and the instructions of the cooling system manufacturer.
Check mechanical and electrical connections.	As specified in the machine maintenance plan, but at least every 1000 hours of operation.
Check motor for silent running, vibrations and bearing noise.	As specified in the machine maintenance plan, but at least every 1000 hours of operation.
Remove dust, chips and other impurities from the motor housing, cooling fins, fan and connections.	Depending on the level of impurity, but after 6 months at the latest. When very dirty, then monthly.

Fig. 14-1: ADF Maintenance Plan

14.5 Troubleshooting



DANGER

Danger of injury due to moved elements! Danger of injury due to hot surfaces!

- ⇒ Do not carry out any maintenance work at machines that are running.
- ⇒ Switch off control unit and machine and wait for the discharge time of the electrical systems before beginning with the fault clearance.
- ⇒ During maintenance work, secure the system against re-starting and against unauthorized use.
- ⇒ Do not work at hot surfaces.

The possible causes for faults at ADF motors can be limited to the following areas:

- Motor encoder or encoder connection
- Internal winding temperature sensor
- Cooling system
- Mechanical damage to the motor
- Mechanical connection to the machine

The encoder and temperature sensor are monitored by the drive controller or the control system and appropriate diagnoses are shown. Observe the instructions of the respective documentation.

In the following, some fault examples are shown with potential causes and work-arounds, without any claims to completeness.

Excessive Temperature at the Motor Housing

Condition The housing temperature of the motor increases to abnormally high values.

- Possible Causes**
1. Breakdown or fault in the cooling system.
 2. Original processing cycle has been changed.
 3. Original motor parameters have been changed.
 4. Motor bearing is worn-out or defective.

- Countermeasures**
1. Check the cooling system. Clean or rinse the cooling circuit as required. Contact the machine manufacturer if the cooling system breaks down.
 2. Check drive sizing and selection for changed requirements. Do not continue work during overloads. Danger of damage!
 3. Re-establish the original parameters. Check sizing of drive when requirements have been changed.
 4. Compare total motor operating period with available bearing lifetime and grease life. Slowly turn the motor shaft manually and check for any bearing noises or vibrations. Contact REXROTH INDRAMAT Service on a breakdown.

Motor Temperature is High, Housing Temperature is Normal

Condition The diagnostics system of the control unit shows unusually high values for the winding temperature via the display or the control software. However, the temperature of the motor housing is normal.

- Possible Causes**
1. Wiring error or cable break in the sensor line.
 2. Diagnostics system is defective.
 3. Failure of the winding temperature sensor (NTC).

- Countermeasures**
1. Check the wiring and the connection of the temperature sensor according to the connection plan.
 2. Check the diagnostics system at the control unit or the control system.
 3. Check the resistance value of the temperature sensor using a multimeter.
 - Set the measuring equipment to resistance measurement.
 - Disconnect the connection of the temperature sensor at the control unit and connect both wires with the measuring equipment (the sensor line is thereby also checked). Check the values according to the following curve.
 - If the sensor is defective, connect the replacement sensor (refer to the following section). If both sensors are defective the motor must be replaced. Contact REXROTH INDRAMAT Service.

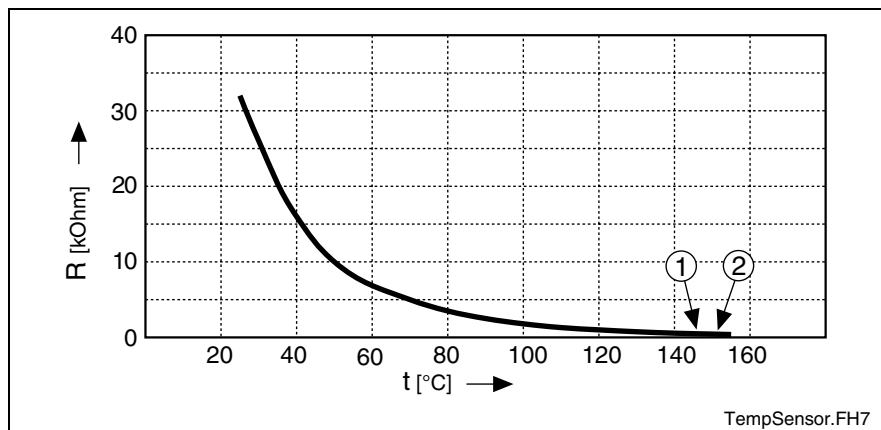

- (1): Temperature warning at 145 °C
 (2): Switch-off at 155 °C

Fig. 14-2: ADF Winding Temperature, NTC Sensor Curve

Connecting the Replacement Sensor

- Motor with Terminal Box**
1. Switch off the system according to the above safety instructions.
 2. Open the terminal box and disconnect the connection of the wire pair - that feeds from the power cable to the temperature sensor - from the terminal strip.
 3. Connect this wire pair from the power cable to the terminal strip contacts of the replacement hot conductor.
 4. Check the electrical resistance of the temperature sensor with the system switched off (instructions in the section above).
 5. After a successful check, close the terminal box. Make sure that the cover seal is correctly seated. Secure the fixing screws using "Locking Device LOCTITE 243" .

Motor with Flange Box

Note: To install and uninstall the contact pins you need special tools. Information on handling and tools is contained in the documentation "Indramat Connection Technology, Assembly and Tools...", Mat.No. 00280895.

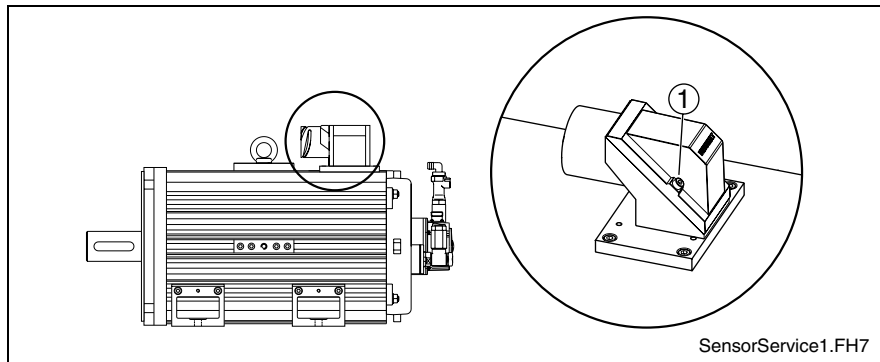

(1): Flange box housing with fixing screws (2x)

Fig. 14-3: ADF Flange Box

1. Switch off the system according to the above safety instructions.
2. Loosen the fixing screws of the flange box housing and carefully lift the lid. Avoid damaging the sealing ring located inside.
3. Using the extraction tool, release the contact pin of the defective temperature sensor from the insulator body.
4. Using the extraction tool, release two unused contact pins from the insulation body and crimp the wires of the replacement sensor onto them.
5. Using the insertion tool, plug the newly contacted pins into the contact openings from step 3. The polarity for NTC-type sensors is irrelevant. Observe instructions in the chapter entitled "Connections".
6. Using the insertion tool, plug the pins of the defective sensor into the remaining contact openings to re-establish the tightness of the insulation body.
7. Make sure that the sealing inside is sitting correctly and then screw the cover onto the flange box housing. Secure the fixing screws using "Locking Device LOCTITE 243" .
8. Check the electrical resistance of the temperature sensor with the system switched off (instructions in the section above).

Motor generates Vibrations

Condition	Vibrations can be heard or felt at the motor.
Possible Causes	<ol style="list-style-type: none"> 1. Driven machine elements are insufficiently balanced or not balanced or insufficiently connected. 2. Motor bearing is worn-out or defective. The existing bearing lifetime or grease life has expired. 3. Motor fixing has become loose 4. Drive system control loop is unstable.
Countermeasures	<ol style="list-style-type: none"> 1. Check the balancing of driven machine elements. Check the key and the keyway. Contact REXROTH INDRAMAT Service if they are damaged. 2. Check the motor for damages. Contact REXROTH INDRAMAT Service on a breakdown. 3. Fix the motor correctly and check for damages. Contact REXROTH INDRAMAT Service on a breakdown. 4. Check the parameterization of the drive system (motor and encoder data). Observe the instructions in the drive controller documentation.

Preset Position is not Reached

Condition	Positioning command from the control system has not been executed exactly or at all. No fault display at the control unit or the control system.
Possible Causes	<ol style="list-style-type: none"> 1. Wiring of the encoder cable is faulty or defective. Pin assignment (encoder signal) in the cable or the plug has possibly been swapped. 2. Shielding of the encoder cable against interference signals is insufficient. 3. Parameterization of the encoder data in the control unit is faulty. 4. Connection between the motor shaft and the machine element has become loose. 5. Encoder is defective.
Countermeasures	<ol style="list-style-type: none"> 1. Check wiring according to the connection plan and the cable condition for damages. 2. Check the shielding; when necessary, enlarge the contact surfaces of the shielding. 3. Correct the parameters. Observe the commissioning protocol. 4. Check the mechanical connection. Do not reuse damaged parts. 5. The motor or the encoder must be replaced. Contact REXROTH INDRAMAT Service on a breakdown.



Various other faults and malfunctions, which do not belong to the motor documentation, might appear in a complex drive & control system. Contact REXROTH INDRAMAT helpdesk and service lines for further assistance. Phone numbers and contacts are listed in the following chapter.

15 Service & Support

15.1 Helpdesk

Unser Kundendienst-Helpdesk im Hauptwerk Lohr am Main steht Ihnen mit Rat und Tat zur Seite. Sie erreichen uns

- telefonisch: **+49 (0) 9352 40 50 60**
über Service Call Entry Center Mo-Fr 07:00-18:00
- per Fax: **+49 (0) 9352 40 49 41**
- per e-Mail: **service@indramat.de**

Our service helpdesk at our headquarters in Lohr am Main, Germany can assist you in all kinds of inquiries. Contact us

- by phone: **+49 (0) 9352 40 50 60**
via Service Call Entry Center Mo-Fr 7:00 am - 6:00 pm
- by fax: **+49 (0) 9352 40 49 41**
- by e-mail: **service@indramat.de**

15.2 Service-Hotline

Außerhalb der Helpdesk-Zeiten ist der Service direkt ansprechbar unter

+49 (0) 171 333 88 26
oder **+49 (0) 172 660 04 06**

After helpdesk hours, contact our service department directly at

+49 (0) 171 333 88 26
or **+49 (0) 172 660 04 06**

15.3 Internet

Ergänzende Hinweise zu Service, Reparatur und Training sowie die **aktuellen** Adressen unserer Service- und Vertriebsbüros finden Sie unter www.indramat.de – einige Angaben in dieser Dokumentation können inzwischen überholt sein.

Außerhalb Deutschlands nehmen Sie bitte zuerst Kontakt mit Ihrem lokalen Ansprechpartner auf.

- Verkaufsniederlassungen
 Niederlassungen mit Kundendienst

Additional notes about service, repairs and training as well as the **actual** addresses of our sales- and service facilities are available on the Internet at www.indramat.de – some information in this documentation may meanwhile be obsolete.

Please contact the sales & service offices in your area first.

- sales agencies
 offices providing service

15.4 Vor der Kontaktaufnahme... - Before contacting us...

Wir können Ihnen schnell und effizient helfen wenn Sie folgende Informationen bereithalten:

1. detaillierte Beschreibung der Störung und der Umstände.
2. Angaben auf dem Typenschild der betreffenden Produkte, insbesondere Typenschlüssel und Seriennummern.
3. Tel./Faxnummern und e-Mail-Adresse, unter denen Sie für Rückfragen zu erreichen sind.

For quick and efficient help, please have the following information ready:

1. Detailed description of the failure and circumstances.
2. Information on the type plate of the affected products, especially type codes and serial numbers.
3. Your phone/fax numbers and e-mail address, so we can contact you in case of questions.

15.5 Kundenbetreuungsstellen - Sales & Service Facilities

Deutschland – Germany

vom Ausland:

(0) nach Landeskennziffer weglassen!

from abroad:

don't dial (0) after country code!

<p>Vertriebsgebiet Mitte Germany Centre</p> <p>Rexroth Indramat GmbH Bgm.-Dr.-Nebel-Str. 2 97816 Lohr am Main</p> <p>Kompetenz-Zentrum Europa</p> <p>Tel.: +49 (0)9352 40-0 Fax: +49 (0)9352 40-4885</p>	<p>SERVICE</p> <p>CALL ENTRY CENTER MO – FR von 07:00 - 18:00 Uhr from 7 am – 6 pm</p> <p>Tel. +49 (0) 9352 40 50 60 service@indramat.de</p>	<p>SERVICE</p> <p>HOTLINE MO – FR von 17:00 - 07:00 Uhr from 5 pm - 7 am + SA / SO</p> <p>Tel.: +49 (0)172 660 04 06 oder / or Tel.: +49 (0)171 333 88 26</p>	<p>SERVICE</p> <p>ERSATZTEILE / SPARES verlängerte Ansprechzeit - extended office time - ♦ nur an Werktagen - only on working days - ♦ von 07:00 - 18:00 Uhr - from 7 am - 6 pm - Tel. +49 (0) 9352 40 42 22</p>
<p>Vertriebsgebiet Süd Germany South</p> <p>Rexroth Indramat GmbH Landshuter Allee 8-10 80637 München Tel.: +49 (0)89 127 14-0 Fax: +49 (0)89 127 14-490 indramat.mue@t-online.de</p>	<p>Gebiet Südwest Germany South-West</p> <p>Bosch Rexroth AG Vertrieb Deutschland – VD-BI Geschäftsbereich Rexroth Indramat Regionalzentrum Südwest Ringstrasse 70 / Postfach 1144 70736 Fellbach / 70701 Fellbach</p> <p>Tel.: +49 (0)711 57 61–100 Fax: +49 (0)711 57 61–125</p>	<p>Vertriebsgebiet Ost Germany East</p> <p>Bosch Rexroth AG Beckerstraße 31 09120 Chemnitz</p> <p>Tel.: +49 (0)371 35 55-0 Fax: +49 (0)371 35 55-333</p>	<p>Vertriebsgebiet Nord Germany North</p> <p>Bosch Rexroth AG Walsroder Str. 93 30853 Langenhagen</p> <p>Tel.: +49 (0) 511 72 66 57-0 Fax: +49 (0) 511 72 66 57-95</p>
<p>Vertriebsgebiet West Germany West</p> <p>Bosch Rexroth AG Vertrieb Deutschland Regionalzentrum West Borsigstrasse 15 40880 Ratingen</p> <p>Tel.: +49 (0)2102 409-0 Fax: +49 (0)2102 409-406</p>	<p>Vertriebsgebiet Mitte Germany Centre</p> <p>Bosch Rexroth AG Gesch.ber. Rexroth Indramat Liliststraße 14-18 63067 Offenbach</p> <p>Tel.: +49 (0) 69 82 00 90-0 Fax: +49 (0) 69 82 00 90-80</p>	<p>Vertriebsgebiet Ost Germany East</p> <p>Bosch Rexroth AG GB Rexroth Indramat GmbH Holzhäuser Str. 122 04299 Leipzig</p> <p>Tel.: +49 (0)341 86 77-0 Fax: +49 (0)341 86 77-219</p>	<p>Vertriebsgebiet Nord Germany North</p> <p>Bosch Rexroth AG Kieler Straße 212 22525 Hamburg</p> <p>Tel.: +49 (0) 40 81 955 966 Fax: +49 (0) 40 85 418 978</p>

Europa (West) - Europe (West)

vom Ausland: (0) nach Landeskennziffer weglassen, **Italien:** 0 nach Landeskennziffer mitwählen
from abroad: don't dial (0) after country code, **Italy:** dial 0 after country code

<p>Austria - Österreich</p> <p>Bosch Rexroth GmbH Bereich Indramat Stachegasse 13 1120 Wien</p> <p>Tel.: +43 (0)1 985 25 40 Fax: +43 (0)1 985 25 40-93</p>	<p>Austria – Österreich</p> <p>Bosch Rexroth G.m.b.H. Gesch.ber. Rexroth Indramat Industriepark 18 4061 Pasching</p> <p>Tel.: +43 (0)7221 605-0 Fax: +43 (0)7221 605-21</p>	<p>Belgium - Belgien</p> <p>Bosch Rexroth nv Gesch.ber. Rexroth Indramat Industrielaan 8 1740 Ternat</p> <p>Tel.: +32 (0)2 5830719 Fax: +32 (0)2 5830731 indramat@rexroth.be</p>	<p>Denmark - Dänemark</p> <p>Bosch Rexroth A/S Zinkvej 6 8900 Randers</p> <p>Tel.: +45 (0)87 11 90 60 Fax: +45 (0)87 11 90 61</p>
<p>Great Britain – Großbritannien</p> <p>Bosch Rexroth Ltd. Rexroth Indramat Division Broadway Lane, South Cerney Cirencester, Glos GL7 5UH</p> <p>Tel.: +44 (0)1285 863000 Fax: +44 (0)1285 863030 sales@indramat.co.uk service@indramat.co.uk</p>	<p>Finland - Finnland</p> <p>Rexroth Mecman Oy Rexroth Indramat division Ansatie 6 017 40 Vantaa</p> <p>Tel.: +358 (0)9 84 91-11 Fax: +358 (0)9 84 91-13 60</p>	<p>France - Frankreich</p> <p>Bosch Rexroth S.A. Division Rexroth Indramat Avenue de la Trentaine BP. 74 77503 CHELLES CEDEX</p> <p>Tel.: +33 (0)164 72-70 00 Fax: +33 (0)164 72-63 00 Hotline: +33 (0)608 33 43 28</p>	<p>France - Frankreich</p> <p>Bosch Rexroth S.A. Division Rexroth Indramat 1270, Avenue de Lardenne 31100 Toulouse</p> <p>Tel.: +33 (0)5 61 49 95 19 Fax: +33 (0)5 61 31 00 41</p>
<p>France - Frankreich</p> <p>Bosch Rexroth S.A. Division Rexroth Indramat 91, Bd. Irène Joliot-Curie 69634 Vénissieux – Cedex</p> <p>Tel.: +33 (0)4 78 78 53 65 Fax: +33 (0)4 78 78 53 62</p>	<p>Italy - Italien</p> <p>Bosch Rexroth S.p.A. Via G. Di Vittoria, 1 20063 Cernusco S/N.MI</p> <p>Tel.: +39 02 2 365 270 Fax: +39 02 700 408 252378</p>	<p>Italy - Italien</p> <p>Bosch Rexroth S.p.A. Via Paolo Veronesi, 250 10148 Torino</p> <p>Tel.: +39 011 224 88 11 Fax: +39 011 220 48 04</p>	<p>Italy - Italien</p> <p>Bosch Rexroth S.p.A. Via del Progresso, 16 (Zona Ind.) 35020 Padova</p> <p>Tel.: +39 049 8 70 13 70 Fax: +39 049 8 70 13 77</p>
<p>Italy - Italien</p> <p>Bosch Rexroth S.p.A. Via Mascia, 1 80053 Castellammare di Stabia NA</p> <p>Tel.: +39 081 8 71 57 00 Fax: +39 081 8 71 68 85</p>	<p>Italy - Italien</p> <p>Bosch Rexroth S.p.A. Viale Oriani, 38/A 40137 Bologna</p> <p>Tel.: +39 051 34 14 14 Fax: +39 051 34 14 22</p>	<p>Netherlands - Niederlande/Holland</p> <p>Bosch Rexroth B.V. Kruisbroeksestraat 1 (P.O. Box 32) 5281 RV Boxtel</p> <p>Tel.: +31 (0)411 65 19 51 Fax: +31 (0)411 65 14 83 indramat@hydraudyne.nl</p>	<p>Netherlands - Niederlande/Holland</p> <p>Bosch Rexroth Services B.V. Kruisbroeksestraat 1 (P.O. Box 32) 5281 RV Boxtel</p> <p>Tel.: +31 (0)411 65 19 51 Fax: +31 (0)411 67 78 14</p>
<p>Norway - Norwegen</p> <p>Bosch Rexroth AS Rexroth Indramat Division Berghagan 1 or: Box 3007 1405 Ski-Langhus 1402 Ski</p> <p>Tel.: +47 (0)64 86 41 00 Fax: +47 (0)64 86 90 62 jul.ruud@rexroth.no</p>	<p>Spain - Spanien</p> <p>Bosch Rexroth S.A. División Rexroth Indramat Centro Industrial Santiga Obradors s/n 08130 Santa Perpetua de Mogoda Barcelona</p> <p>Tel.: +34 9 37 47 94 00 Fax: +34 9 37 47 94 01</p>	<p>Spain - Spanien</p> <p>Goimendi S.A. División Rexroth Indramat Parque Empresarial Zuatzu C/ Francisco Grandmontagne no.2 20018 San Sebastian</p> <p>Tel.: +34 9 43 31 84 21 - service: +34 9 43 31 84 56 Fax: +34 9 43 31 84 27 - service: +34 9 43 31 84 60 satindramat-goimendi@adegi.es</p>	<p>Sweden - Schweden</p> <p>Rexroth Mecman Svenska AB Rexroth Indramat Division Varuvägen 7 125 81 Stockholm</p> <p>Tel.: +46 (0)8 727 92 00 Fax: +46 (0)8 647 32 77</p>
<p>Sweden - Schweden</p> <p>Rexroth Mecman Svenska AB Indramat Support Ekvändan 7 254 67 Helsingborg</p> <p>Tel.: +46 (0) 42 38 88 -50 Fax: +46 (0) 42 38 88 -74</p>	<p>Switzerland West - Schweiz West</p> <p>Bosch Rexroth Suisse SA Département Rexroth Indramat Rue du village 1 1020 Renens</p> <p>Tel.: +41 (0)21 632 84 20 Fax: +41 (0)21 632 84 21</p>	<p>Switzerland East - Schweiz Ost</p> <p>Bosch Rexroth Schweiz AG Geschäftsbereich Indramat Hemrietstrasse 2 8863 Buttikon</p> <p>Tel. +41 (0) 55 46 46 205 Fax +41 (0) 55 46 46 222</p>	

Europa (Ost) - Europe (East)

vom Ausland: (0) nach Landeskennziffer weglassen
from abroad: don't dial (0) after country code

Czech Republic - Tschechien	Czech Republic - Tschechien	Hungary - Ungarn	Poland – Polen
Bosch -Rexroth, spol.s.r.o. Hviezdoslavova 5 627 00 Brno Tel.: +420 (0)5 48 126 358 Fax: +420 (0)5 48 126 112	DEL a.s. Strojírenská 38 Zdar nad Sázavou 591 01 Czech republic Tel.: +420 616 64 3144 Fax: +420 616 216 57	Bosch Rexroth Kft. Angol utca 34 1149 Budapest Tel.: +36 (1) 364 00 02 Fax: +36 (1) 383 19 80	Bosch Rexroth Sp.zo.o. Biuro Poznan ul. Dabrowskiego 81/85 60-529 Poznan Tel.: +48 061 847 64 62 /-63 Fax: +48 061 847 64 02
Rumania - Rumänien	Russia - Russland	Russia - Russland	Turkey - Türkei
Bosch Rexroth Sp.zo.o. Str. Drobety nr. 4-10, app. 14 70258 Bucuresti, Sector 2 Tel.: +40 (0)1 210 48 25 +40 (0)1 210 29 50 Fax: +40 (0)1 210 29 52	Bosch Rexroth Wolokolamskoje Chaussee 73 Zimmer 406, 408 RUS – 123424 Moskau Tel.: +7 095/ 232 08 34 +7 095/ 232 08 35 Fax: +7 095/ 232 08 36 info.rex@rexroth.ru	ELMIS 10, Internationalnaya Str. 246640 Gomel, Belarus Tel.: +375/ 232 53 42 70 Fax: +375/ 232 53 37 69 elmis_ltd@yahoo.com	Bosch Rexroth Otomasyon San & Tic. A.S. Fevzi Cakmak Cad No. 3 34630 Sefaköy Istanbul Tel.: +90 212 541 60 70 Fax: +90 212 599 34 07
Slowenia - Slowenien			
DOMEL Otoki 21 64 228 Zelezniki Tel.: +386 5 5117 152 Fax: +386 5 5117 225 brane.ozebek@domel.si			

Africa, Asia, Australia – incl. Pacific Rim

vom Ausland: (0) nach Landeskennziffer weglassen!
from abroad: don't dial (0) after country code!

<p>Australia - Australien</p> <p>AIMS - Australian Industrial Machinery Services Pty. Ltd. Unit 3/45 Horne ST Campbellfield , VIC 3061 Melbourne Tel.: +61 (0) 393 590 228 Fax: +61 (0) 393 590 286 Hotline: +61 (0) 419 369 195 terryobrien@aimservices.com.au</p>	<p>Australia - Australien</p> <p>Bosch Rexroth Pty. Ltd. No. 7, Endeavour Way Braeside Victoria, 31 95 Melbourne Tel.: +61 (0)3 95 80 39 33 Fax: +61 (0)3 95 80 17 33 mel@rexroth.com.au</p>	<p>China</p> <p>Bosch Rexroth Ltd. Wai Gaoqiao Free Trade Zone No.122, Fu Te Dong Yi Road Shanghai 200131 - P.R.China Tel.: +86 21 58 66 30 30 Fax: +86 21 58 66 55 23 roger.shi_sh@boschrexroth.com.cn</p>	<p>China</p> <p>Bosch Rexroth (China) Ltd. 15/F China World Trade Center 1, Jianguomenwai Avenue Beijing 100004, P.R.China Tel.: +86 10 65 05 03 80 Fax: +86 10 65 05 03 79</p>
<p>China</p> <p>Bosch Rexroth (China) Ltd. A-5F., 123 Lian Shan Street Sha He Kou District Dalian 116 023, P.R.China Tel.: +86 411 46 78 930 Fax: +86 411 46 78 932</p>	<p>China</p> <p>Bosch Rexroth (Changzhou) Co.Ltd. Guangzhou Repres. Office Room 1014-1016, Metro Plaza, Tian He District, 183 Tian He Bei Rd Guangzhou 510075, P.R.China Tel.: +86 20 8755-0030 +86 20 8755-0011 Fax: +86 20 8755-2387</p>	<p>Hongkong</p> <p>Bosch Rexroth (China) Ltd. 6th Floor, Yeung Yiu Chung No.6 Ind Bldg. 19 Cheung Shun Street Cheung Sha Wan, Kowloon, Hongkong Tel.: +852 22 62 51 00 Fax: +852 27 41 33 44 alexis.siu@boschrexroth.com.hk</p>	<p>India - Indien</p> <p>Bosch Rexroth (India) Ltd. Rexroth Indramat Division Plot. A-58, TTC Industrial Area Thane Turbhe Midc Road Mahape Village Navi Mumbai - 400 701 Tel.: +91 (0)22 7 61 46 22 Fax: +91 (0)22 7 68 15 31</p>
<p>India - Indien</p> <p>Bosch Rexroth (India) Ltd. Rexroth Indramat Division Plot. 96, Phase III Peenya Industrial Area Bangalore - 560058 Tel.: +91 (0)80 8 39 73 74 Fax: +91 (0)80 8 39 43 45</p>	<p>Indonesia - Indonesien</p> <p>PT. Rexroth Wijayakusuma Building # 202, Cilandak Commercial Estate Jl. Cilandak KKO, Jakarta 12560 Tel.: +62 21 7891169 (5 lines) Fax: +62 21 7891170 - 71</p>	<p>Japan</p> <p>Bosch Rexroth Automation Corp. Service Center Japan Yutakagaoka 1810, Meito-ku, NAGOYA 465-0035, Japan Tel.: +81 (0)52 777 88 41 +81 (0)52 777 88 53 +81 (0)52 777 88 79 Fax: +81 (0)52 777 89 01</p>	<p>Japan</p> <p>Bosch Rexroth Automation Corp. Rexroth Indramat Division 1F, I.R. Building Nakamachidai 4-26-44, Tsuzuki-ku YOKOHAMA 224-0041, Japan Tel.: +81 (0)45 942 72 10 Fax: +81 (0)45 942 03 41</p>
<p>Korea</p> <p>Bosch Rexroth-Korea Ltd. 1515-14 Dadae-Dong, Saha-Ku Rexroth Indramat Division Pusan Metropolitan City, 604-050 Republic of South Korea Tel.: +82 (0)51 26 00 741 Fax: +82 (0)51 26 00 747 gyhan@rexrothkorea.co.kr</p>	<p>Malaysia</p> <p>Bosch Rexroth Sdn.Bhd. Head Office No. 3, Block B, Jalan SS 13/5 Subang Jaya Industrial Estate 47500 Petaling Jaya - Selangor Tel.: +60 (0) 3 73 44 870 Fax: +60 (0) 3 73 44 864 hockhwa@hotmail.com</p>	<p>Singapore - Singapur</p> <p>Robert Bosch (SEA) Pte Ltd. Dept. RBRSI-R/SAT 38-C Jalan Pemimpin Singapore 577180 Tel.: +65 35 05 470 Fax: +65 35 05 313 kenton.peh@sg.bosch.com</p>	<p>South Africa - Südafrika</p> <p>TECTRA Automation (Pty) Ltd. 28 Banfield Road, Industria North RSA - Maraisburg 1700 Tel.: +27 (0)11 673 20 80 Fax: +27 (0)11 673 72 69 Hotline: +27 (0)82 903 29 23 georgv@tectra.co.za</p>
<p>Taiwan</p> <p>Rexroth Uchida Co., Ltd. No.17, Lane 136, Cheng Bei 1 Rd., Yung Kang, Tainan Hsien Taiwan, R.O.C. Tel.: +886 (0)6 25 36 565 Fax: +886 (0)6 25 34 754 indramat@mail.net.tw</p>	<p>Thailand</p> <p>NC Advance Technology Co. Ltd. 59/76 Moo 9 Ramintra road 34 Tharang, Bangkhnen, Bangkok 10230 Tel.: +66 2 943 70 62 +66 2 943 71 21 Fax: +66 2 509 23 62 sonkawin@hotmail.com</p>		

Nordamerika – North America

USA Hauptniederlassung - Headquarters Bosch Rexroth Corporation Rexroth Indramat Division 5150 Prairie Stone Parkway Hoffman Estates, IL 60192-3707 Tel.: +1 847 6 45 36 00 Fax: +1 847 6 45 62 01 service@indramat.com	USA Central Region - Mitte Bosch Rexroth Corporation Rexroth Indramat Division Central Region Technical Center Auburn Hills, MI 48326 Tel.: +1 248 3 93 33 30 Fax: +1 248 3 93 29 06	USA Southeast Region - Südwest Bosch Rexroth Corporation Rexroth Indramat Division Southeastern Technical Center 3625 Swiftwater Park Drive Suwanee, Georgia 30174 Tel.: +1 770 9 32 32 00 Fax: +1 770 9 32 19 03	USA SERVICE-HOTLINE - 7 days x 24hrs - +1-800-860-1055
USA East Region –Ost Bosch Rexroth Corporation Rexroth Indramat Division Charlotte Regional Sales Office 14001 South Lakes Drive Charlotte, North Carolina 28273 Tel.: +1 704 5 83 97 62 +1 704 5 83 14 86	USA Northeast Region – Nordost Bosch Rexroth Corporation Rexroth Indramat Division Northeastern Technical Center 99 Rainbow Road East Granby, Connecticut 06026 Tel.: +1 860 8 44 83 77 Fax: +1 860 8 44 85 95	USA West Region – West Bosch Rexroth Corporation 7901 Stoneridge Drive, Suite 220 Pleasant Hill, California 94588 Tel.: +1 925 227 10 84 Fax: +1 925 227 10 81	
Canada East - Kanada Ost Bosch Rexroth Canada Corporation Burlington Division 3426 Mainway Drive Burlington, Ontario Canada L7M 1A8 Tel.: +1 905 335 55 11 Fax: +1 905 335-41 84 michael.moro@boschrexroth.ca	Canada West - Kanada West Bosch Rexroth Canada Corporation 5345 Goring St. Burnaby, British Columbia Canada V7J 1R1 Tel. +1 604 205-5777 Fax +1 604 205-6944 david.gunby@boschrexroth.ca		

Südamerika – South America

Argentina - Argentinien Bosch Rexroth S.A.I.C. "The Drive & Control Company" Acassuso 48 41/47 1605 Munro Prov. Buenos Aires Tel.: +54 (0)11 4756 01 40 Fax: +54 (0)11 4756 01 36 mannesmann@mannesmannsaic.com.ar	Argentina - Argentinien NAKASE Servicio Tecnico CNC Calle 49, No. 5764/66 1653 Villa Balester Prov. - Buenos Aires Tel.: +54 (0) 11 4768 36 43 Fax: +54 (0) 11 4768 24 13 nakase@usa.net nakase.com	Brazil - Brasilien Bosch Rexroth Ltda. Av. Tégula, 888 Ponte Alta, Atibaia SP CEP 12942-440 Tel.: +55 (0)11 4414 56 92 +55 (0)11 4414 56 84 Fax sales: +55 (0)11 4414 57 07 Fax serv.: +55 (0)11 4414 56 86 alexandre.wittwer@rexroth.com.br	Brazil - Brasilien Bosch Rexroth Ltda. R. Dr.Humberto Pinheiro Vieira, 100 Distrito Industrial [Caixa Postal 1273] BR - 89220-390 Joinville - SC Tel./Fax: +55 (0)47 473 58 33 Mobil: +55 (0)47 9974 6645 prochnow@zaz.com.br
Mexico Bosch Rexroth S.A. de C.V. Calle Neptuno 72 Unidad Ind. Vallejo MEX - 07700 Mexico, D.F. Tel.: +52 5 754 17 11 +52 5 754 36 84 +52 5 754 12 60 Fax: +52 5 754 50 73 +52 5 752 59 43	Columbia - Kolumbien Reflutec de Colombia Ltda. Calle 37 No. 22-31 Santafé de Bogotá, D.C. Colombia Tel.: +57 1 368 82 67 +57 1 368 02 59 Fax: +57 1 268 97 37 reflutec@inter.net.co		

16 Appendix

16.1 List of standards

Standard	Edition	Title	Conformabilities
89/336/EWG	1989-05-03	COUNCIL DIRECTIVE of 3 May 1989 on the approximation of the laws of the Member States relating to electromagnetic compatibility (89/336/EEC)	-
89/392/EWG replaced by 98/37/EG	1998-06-22	Directive 98/37/EC of the european parliament and of the council of 22 June 1998 on the approximation of the laws of the member states relating to machinery	-
DIN VDE 0298-4	1998-11	Application of cables and cords in power installations - Part 4: Recommended current-carrying capacity for sheathed and non-sheathed cables for fixed wirings in buildings and for flexible cables and cords	-
DIN 332-2	1983-05	Center holes 60° with thread for shaft ends for rotating electrical machines	-
DIN VDE 0472-803 replaced by DIN EN 60811-2-1	1996-03	Insulating and sheathing materials of electric cables - Common test methods - Part 2-1: Methods specific to elastomeric compounds; ozone resistance, hot set and mineral oil immersion tests (IEC 60811-2-1:1998); German version EN 60811-2-1:1998	EN 60811-2-1(1998-08) IEC 60811-2-1(1998-04)
IEC 721-1 replaced by DIN IEC 60721-1	1997-02	Classification of environmental conditions - Part 1: Environmental parameters and their severities (IEC 60721-1:1990 + A1:1992 + A2:1995); German version EN 60721-1:1995 + A2:1995	EN 60721-1(1995-04) EN 60721-1/A2(1995-07) IEC 60721-1(1990-12) IEC 60721-1 AMD 1 (1992-12) IEC 60721-1 AMD 2 (1995-04)
IEC 721-3-3 replaced by DIN EN 60721-3-3	1995-09	Classification of environmental conditions - Part 3: Classification of groups of environmental parameters and their severities; section 3: Stationary use at weatherprotected locations (IEC 60721-3-3:1994); German version EN 60721-3-3:1995 Changed by DIN EN 60721-3-3/A2 from July 1997	EN 60721-3-3(1995-01) IEC 60721-3-3(1994-12)
DIN ISO 2373 replaced by DIN EN 60034-14	1997-09	Rotating electrical machines - Part 14: Mechanical vibration of certain machines with shaft heights 56 mm and higher; measurement, evaluation and limits of vibration (IEC 60034-14:1996); German version EN 60034-14:1996	EN 60034-14(1996-12) IEC 60034-14(1996-11)
DIN 6885-1	1968-08	Drive Type Fastenings without Taper Action; Parallel Keys, Keyways, Deep Pattern for Machine Tools, Dimensions and Application	-
DIN 42955	1981-12	Tolerances of shaft extension run-out and of mounting flanges for rotating electrical machinery, test	IEC 60072(1971)
EN 50178	1998-04	Electronic equipment for use in power installations; German version EN 50178:1997	EN 50178(1997-10)
EN 60034-1	2000-09	Rotating electrical machines - Part 1: Rating and performance (IEC 60034-1:1996, modified + A1:1997 + A2:1999); German version EN 60034-1:1998 + A1:1998 + A2:1999	EN 60034-1(1998-05); EN 60034-1/A1(1998-05); EN 60034-1/A2(1999-08); IEC 60034-1(1996-11); IEC 60034-1 AMD 1(1997-06); IEC 60034-1 AMD 2(1999-05)
EN 60034-7	1996-06	Rotating electrical machines - Part 7: Classification of types of constructions and mounting arrangements (IM code) (IEC 60034-7:1992); German version EN 60034-7:1993	EN 60034-7(1993-01); IEC 60034-7(1992-12)
DIN EN 60204-1	1998-11	Safety of machinery - Electrical equipment of machines - Part 1: General requirements (IEC 60204-1:1997 + Corrigendum 1998); German version EN 60204-1:1997	EN 60204-1(1997-12); IEC 60204-1(1997-10)
DIN EN 60529	2000-09	Degrees of protection provided by enclosures (IP code) (IEC 60529:1989 + A1:1999); German version EN 60529:1991 + A1:2000	EN 60529(1991-10); EN 60529/A1(2000-02); IEC 60529(1989-11); IEC 60529 AMD 1(1999-11)

Fig. 16-1: Standards

17 Glossary

Feedback

Term used by Rexroth Indramat for encoder systems. These include incremental rotary encoders, geared encoders and resolvers. Example: Digital Servo Feedback DSF (Option "6" for ADF).

Deep-groove ball bearing

Universal type of bearing suitable for accepting low to medium radial and axial forces. Low-noise when running. Suitability for high speeds. Part of the family of antifriction bearings. Standard bearing type for ADF motors.

Cylinder roller bearing

Single-row bearing design for the "reinforced bearing" option for accepting higher forces. Suitability for low speeds. Operation only permissible with permanently operating radial force.

Feather

Same as "key". Standardized definition, refer to IEC 60050-411-43-14. Half-wedge balancing or "Balancing with Key" can result in disadvantages in the application: When the hub length of the driven machine element is shorter than the length of the key nut then a remaining imbalance remains when the entire key is inserted..

NTC

Abbreviation for "Negative Temperature Coefficient". General term for temperature sensors based on electrical resistors with the following mode of operation: The higher the temperature the lower the electrical resistance.

18 Index

A

- Accessories 9-1
- ADF104
 - data sheet 5-1
 - dimensions sheet 5-4
 - grease life 5-5
 - shaft load 5-6
 - technical data 5-1
 - type code 5-2
- ADF134
 - data sheet 6-1
 - dimensions sheets 6-4
 - grease life 6-7
 - shaft load 6-8
 - technical data 6-1
 - type code 6-2
- ADF164
 - data sheet 7-1
 - dimensions sheets 7-4
 - grease life 7-5
 - shaft load 7-6
 - technical data 7-1
 - type code 7-2
- ADF184
 - data sheet 8-1
 - dimensions sheet 8-4
 - grease life 8-5
 - shaft load 8-6
 - technical data 8-1
 - type code 8-2
- Ambient temperature 11-1
- Application
 - guidelines 11-1
 - utilization 11-1
- Appropriate use
 - applications 2-2
 - Introduction 2-1
- Axial load 11-14

B

- Balancing 11-10
- base assembly 13-1
- Bearing 4-4, 11-12
 - axial load 11-14
 - breakdown 11-14
 - cylinder roller bearing 11-12, 17-1
 - deep-groove ball bearing 11-12, 17-1
 - grease life 11-14
 - lifetime 11-14, 11-15
 - options 11-12
 - radial forces 11-12
 - radial load 11-13
 - reinforced 11-12
 - running friction 11-12
 - selection 11-16
 - wear 11-14
- Brake 11-7
 - connection 10-9
 - energy 11-8
 - load 11-8
 - lock 11-7
 - lock delay 11-7
 - unlock 11-7

C

- Cable selection 10-1
- Checks
 - customer checks 12-1
 - factory checks 12-1
 - high-voltage test 12-1
- Class of protection 11-3
- Command set-point polarity 14-1
- Commissioning 14-1
 - protocol 14-1
- Condition on delivery 12-1
- Connections 10-1
 - angular connector 10-8
 - bayonet joint 10-4
 - brake 10-9
 - connection thread 10-10
 - cooling 4-3
 - diameter 10-10
 - encoder connection 10-8
 - fittings 10-11, 10-12
 - flange socket 10-4
 - inlet 10-10
 - motor cooling 10-10
 - operating pressure 10-10
 - outlet 10-10
 - polarity 10-8
 - power connection 10-2
 - power flange box 10-3
 - temperature sensor 10-9
 - terminal board 10-6
 - terminal box 10-5, 10-6
 - terminal strip 10-6
 - tube connection 10-12
- Cooling 11-18
 - additives 11-19
 - coolant 11-18
 - coolant temperature 11-19
 - corrosion 11-18
- Corrosion 12-2

D

- Disassembly 14-2
- Discharge time 14-2
- Documentation 1-3
- Drive shaft 4-4, 11-10

E

- Electrical connection, *see also* Connections 13-3
- Encoder 11-9, 17-1
 - compatibility 11-9
 - connection 10-8, 11-9
 - I²C interface 11-9
 - incremental encoder 11-9
 - multiturn 11-9
 - single turn 11-9
- Environmental conditions 11-2

F

- Fan
 - direction of revolution 14-1
 - maintenance 14-3
- Feather, *see also* Key 17-1
- Feedback *refer to* Encoder
- flange assembly 13-1

G

Glossary 17-1
Grease life 11-12, 11-14, 11-15

H

Handling 12-1
High-voltage test, *refer also to* Checks 12-1
Holding brake, *see also* Brake 4-3

I

Identification 12-2
Imbalance 11-10
Inappropriate use 2-2
 Consequences, Discharge of liability 2-1
Installation 11-4, 13-1
 altitude 11-1
 base assembly 11-5
 mechanical 13-1
 safety 13-1
 vertical assembly 11-6, 11-11
Insulation resistance 12-1

K

Key 4-4, 11-10
 graded key 11-10
Keyway 4-4, 11-10

L

Labyrinth seal 9-1
Length of motor 4-1
Lifetime 11-14

M

Maintenance 14-3
 measures 14-3
 plan 14-3
Mean speed 11-13, 11-14
Motor bearing, *refer also to* Bearing 11-12
Motor encoder *refer to* Encoder
Motor feedback *refer to* Encoder
Motor size 4-1
Mounting 13-2
Mounting positions 11-4

N

NTC 10-9, 11-17, 17-1

O

Operating conditions 11-1
Operation 14-1

P

positioning command 14-1
Power connection
 output direction 4-2
 position 4-2

R

Radial forces 11-5
Radial shaft seal ring 11-11

S

Safety Instructions for Electric Servo Drives and Controls 3-1
Shaft end, Side B 4-4
Shaft load 11-12
Shaft seal ring 11-11
Shocks 11-2
Shutdown 14-2
star connection 4-3
Storage 12-2

T

Temperature Sensor 11-17
Terminal boxes refer to Connections
Tightness 11-11
Transport 12-1
Troubleshooting 14-4
Type code ADF 4-1
Type plate 12-2

U

Use See Appropriate use and inappropriate use

V

Vibration
level 11-17
severity grade 4-4
Sinusoidal 11-2
speed 11-17

W

Weight compensation 11-7
Windings
code 4-3
temperature 14-5

Bosch Rexroth AG
Electric Drives and Controls
P.O. Box 13 57
97803 Lohr, Germany
Bgm.-Dr.-Nebel-Str. 2
97816 Lohr, Germany
Phone +49 (0)93 52-40-50 60
Fax +49 (0)93 52-40-49 41
service.svc@boschrexroth.de
www.boschrexroth.com



R911273934